

OPERATING & MAINTENANCE INSTRUCTION MANUAL WITH SPARE PART LIST

(Guarantee will be void if not used as instructed in this manual)



WIRE ROPE ELECTRIC HOIST
SMD 5
5T - 4/2 FALL

INDEX

1. Important Information & Warning	3
2. Commissioning Check List	9
3. Erection & Commissioning	10
4. Safe Operating Procedures	12
5. Recommended inspection and maintenance schedule	13
6. Assembly & List of Spare parts	15
7. User information Hoist & Trolley Brake	22
8. Wiring Diagrams & List of Electrical Spares	28
9. Maintenance & Handling	30

Important Information and Warnings

Terms and Summary

This manual provides important information for personnel involved with the installation, operation and maintenance of this product. Although you may be familiar with this or similar equipment, it is strongly recommended that you read this manual before installing, operating or maintaining the product.

Danger, Warning, Caution and Notice - Throughout this manual there are steps and procedures that can present hazardous situations. The following signal words are used to identify the degree or level of hazard seriousness.

DANGER :- Danger indicates an imminently hazardous situation which, if not avoided, will result in death or serious injury, and property damage

WARNING :- Warning indicates an imminently hazardous situation which, if not avoided, could result in death or serious injury, and property damage.

CAUTION :- Caution indicates a potentially hazardous situation which, if not avoided, may result minor or moderate injury or property damage.

NOTICE :- Notice is used to notify people of installation, operation, or maintenance information which is important but not directly hazard-related.

CAUTION

These general instructions deal with the normal installation, operation, and maintenance situations encountered with the equipment described herein. The instructions should not be interpreted to anticipate every possible contingency or to anticipate the final system, crane, or configuration that uses this equipment. For systems using the equipment covered by this manual, the supplier and owner of the system are responsible for the system's compliance with all applicable industry standards, and with all applicable federal, state and local regulations/codes.

This manual includes instructions and parts information for a variety of trolley and hoist types. Therefore, all instructions and parts information may not apply to any one type or size of specific trolley or hoist. Disregard those portions of the instructions that do not apply.

Record your hoist and trolley's Product Code and Serial Number on the front cover of this manual for identification and future reference to avoid referring to the wrong manual for information or instructions on installation, operation, inspection, maintenance, or parts

Use only Indef authorized replacement parts in the service and maintenance of this trolley.

CAUTION

Equipment described herein is not designed for and **MUST NOT** be used for lifting, supporting, or transporting people, or for lifting or supporting loads over people.

Equipment described herein should not be used in conjunction with other equipment unless necessary and/or required safety devices applicable to the system, crane, or application are installed by the system designer, system manufacturer, crane manufacturer, installer, or user.

Modifications to upgrade, rerate, or otherwise alter this equipment shall be authorized only by the original equipment manufacturer.

Failure to read and comply with any one of the limitations noted herein can result in serious bodily injury or death, and/or property damage.

The angle between rope and plane perpendicular to the axis of the drum shall not exceed 5° (As per IS 3938 6.1.1.2).

Hoists shall not be operated unless the hoist unit is centered over the load, except when authorized by a qualified person who has determined that the components of the hoist and its mounting will not be overstressed. Should it be necessary to pick a load that is not centered under the hoist unit, precautions should be taken to control the swing of the load when it is picked clear of its support.

DANGER

HAZARDOUS VOLTAGES ARE PRESENT IN THE CONTROL BOX, OTHER ELECTRICAL COMPONENTS, AND CONNECTIONS BETWEEN THESE COMPONENTS.

Before performing ANY mechanical or electrical maintenance on the equipment, de-energize (disconnect) the main switch supplying power to the equipment; and lock and tag the main switch in the de-energized position.

Only trained and competent personnel should inspect and repair this equipment.



Information

This symbol indicates tips and useful information.

Warning Tag and Labels

The warning tag illustrated below in Figure is supplied with each hoist and trolley shipped from the factory. If the tag is not attached to the pendant cord for your hoist/trolley, order a tag from your dealer and fix it. Read and obey all warnings attached to this Hoist/Trolley. Tag is not shown in actual size.

WARNING

IMPROPER use of powered Hoist could result in death
Or serious injury.

To avoid these hazards:

- ▶ ALWAYS read owner's manual and safety instructions.
- ▶ Do NOT lift more than rated load.
- ▶ Do NOT lift or transport loads over or near people.
- ▶ Do NOT use a hoist for lifting supporting or transporting people.
- ▶ Do NOT operate unless load is centered under hoist.
- ▶ Do NOT support a load on the tip of the hook
- ▶ Do NOT use a hoist if the hook latch is missing or broken.
- ▶ Do NOT remove or obscure the warning labels.
- ▶ Do NOT run the load chain or wire rope over a sharp edge.
- ▶ Do NOT use the load chain or wire rope as a sling.
- ▶ Do NOT operate beyond the travel limits of the hook or load block.
- ▶ Do NOT use a twisted, kinked, damaged, or stretched load chain or wire rope.
- ▶ Do NOT operate a wire rope hoist with a wire rope that is not properly seated in its groove.

CONDITIONS WHERE WARRANTY WILL BE VOID / NOT APPLICABLE

HHL does not provide reimbursement for maintenance and visit charges for items such as: brake adjustments, lubrication oil changes, or any other item or activity deemed solely by HHL to be maintenance related.

HHL will not be liable for damage or malfunction and consequently warranty resulting from:

- a. Lack of maintenance.
- b. Use of improper or insufficient lubricants
- c. Supply voltage high/low or insufficient.
- d. Environmental conditions (including but not limited to extreme temperatures, humidity and corrosive environments).
- e. Outdoor applications where HHL is not intimated and recommendations for protection from the elements are not followed.
- f. Misuse or abuse (including but not limited to overloading, shock loading, or side / angular lifting / pulling).
- g. Use of parts other than genuine HHL replacement parts.
- h. Improper repairs or maintenance.
- i. Modifications not approved by HHL.
- j. Improper handling of product after it leaves HHL factory.
- k. Fire, accidents, or acts of God or nature, including but not limited to floods, hurricanes and lightning.
- l. Any piece of equipment not supplied by Hercules Hoists Limited, is installed on products.
- m. Malfunction or damage caused by items added to Hercules Hoists Limited products, including but not limited to controls and control components.
- n. Relocation of hoist / equipment without proper installation and commissioning by HHL / ABP.
- o. Misalignment in existing / installed Crane rail and hoist monorail, improper existing power feed track.

Operational cause Note

Terms and Summary

Overhead crane & hoists are typically designed to lift objects vertically. The specific guide lines are mentioned in respective IS standard .

Sometimes, however, operators attempt to make a side pull or cross pull or use the hoist horizontally to lift an object that is not directly underneath it.

This can cause damage to hoist.

Probable failures/Risks:

- ▶ Side pulling can cause damage to various hoist parts – Load Chain Wheel, Chain Guide Roller, Chain Stripper, Hook and hook latch assembly, in electric Chain Hoists the load chain guide and chain stripper and in Wire Rope Hoists the rope drum, rope guide and the rope itself.
- ▶ Additionally, it may place the operator and personnel working near the crane at risk for injury.
- ▶ One of the main risks for an operator is load swing, which can damage the load or cause injury to the operator. In extreme cases, there might be a load drop.
- ▶ A rope that has been worn by side pulls may also snap and lead to a loss in control of the load.
- ▶ Cross pull or side pull may affect on monorail beam flanges, the beam web may deflect / distort, and beam flanges may wear causing uneven sides of beam.
- Preventing side pulls could lead to increases in both the safety and the lifetime of the components, customer should be educated at every interaction opportunity.
- The unfortunate prevalence of cross pulling-related accidents and maintenance needs repeated replacement of parts like chain guider roller, chain stripper, hook latch assembly, rope guide related parts i.e set of rope guide ring, spring and rope guide joining bracket.

Operational Note:

- Please be aware that as a safety feature, this rope guide ring is designed to snap in the event of the wrong usage of the rope hoist. As per IS 3938-2005 the angular lifting / pulling of dead weight is not allowed in wire rope hoist. If any user puts the rope hoist to such an application, the rope guide ring will not allow to perform the lifting. The rope guide ring will break if the fleet angle is more than 5 Deg. including angle between point of lift and dead weight kept on floor.
- The specific instruction in Do's and Don'ts is given hoist operating and maintenance manual. Those guidelines are based on past experience and safety standards of operation.
- The hoist in tandem application cannot be used because the load lifting speed and effort are not balanced in manual hoisting operation. Most important is load required to be centered under hoist and load line of trolley centre and hook seating diameter centre should match. The hoists are designed for lifting load vertically. This phenomenon is applicable for all hoisting equipment's.

If hoist not used in proper way as mentioned above the warranty claims will not be accepted. Indicative list of parts not covered under warranty.

Indicative list of parts not covered under warranty:

1	Hoist Motor Winding
2	Wire Rope
3	Safety Latch assembly
4	Brake Disc – Hoist and Trolley
5	Brake Coil – Hoist and Trolley
6	Hoist and Cross Travel Limit Switch
7	Trolley Motor Winding
8	Pendent control
9	Relay and Fuse
10	Control Transformer
11	Special Control Switchgears

This can cause damage to hoist

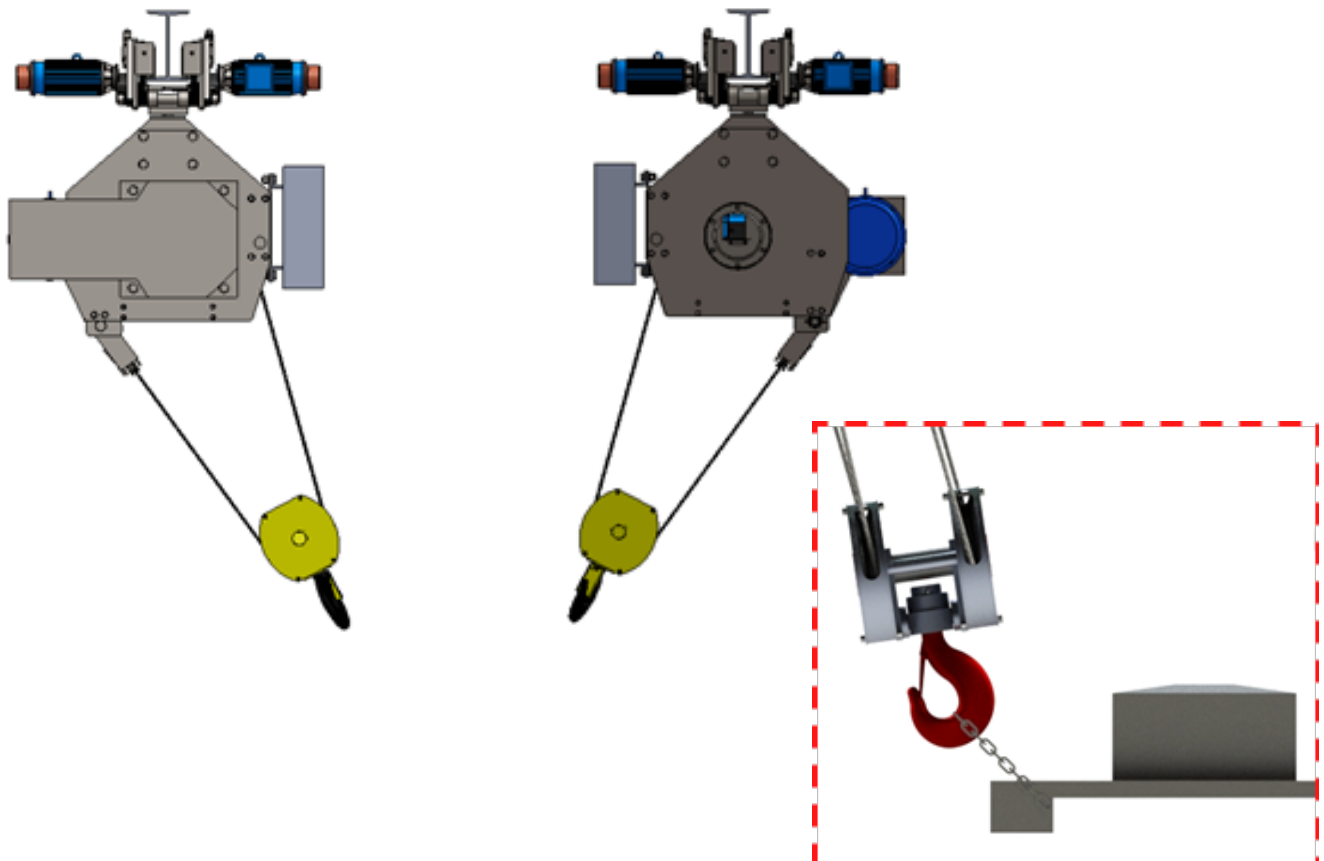

COMMISSIONING CHECK LIST (WRH)

1. Limit Switch: Check all limit switches like over hoisting, over lowering, right & left & emergency Check the direction of motions w.r.t. Pendant buttons change phase sequence if required. This is very important safety requirement.
2. Sufficiency of lift: Set the bottom Limit switch so that hook touches the floor & no further Loosening of wire rope takes place. Set the top limit switch so that safe headroom is maintained between hoist body and lower block. Ensure that rope is not rubbing between L.B.
3. Angular Loading: Check that equipment is not subjected to angular loading. Ensure that equipment is installed at proper place proper hook approaches are used to prevent this.
4. Counter weight assembly: Ensure that counter weights are correctly assembled for balancing of trolley bolts are properly locked & tightened.
5. Noise level: Observed that there is no abnormal noise in Hoist and travel motion.
6. Greasing: Apply grease to the rope for full length & rope guide & ensure free movement
7. Name plate data: Note hoist, motor nos & record them on Instruction manual for future use.
8. Abnormal factors: Excessive dust, temp, humidity, chemical fumes, leakages etc. Report them.
9. Brake setting: Ensure that brake operation is not sluggish & load is not slipping.
This is to certify that equipment is commissioned on and found satisfactory for use.

ERECTION & COMMISSIONING

Hoist has been designed for ease of erection. After removing side and top frames of wooden box you will find Hoist is bolted on the wooden bottom frames like pallet which can be lifted by fork lift truck.

Before erection of hoist adjust flange width of trolley to suit beam size providing equal numbers of washers on both sides between trolley side plate and suspension of hoist.

Check the distance between the wheel flanges. It should be 3 to 8mm more than the width of runway beam flange.

After adjusting the flange width check gear box, oil level, greasing of wire rope, trolley gears and pinions and then install the hoist on beam and remove wooden frame and packing girders. Contact the hoist to 415 v, 3 phase power supply with 2.5mm sq. copper cable.

(CAUTION – DO NOT FORGET TO CONNECT EARTHING)

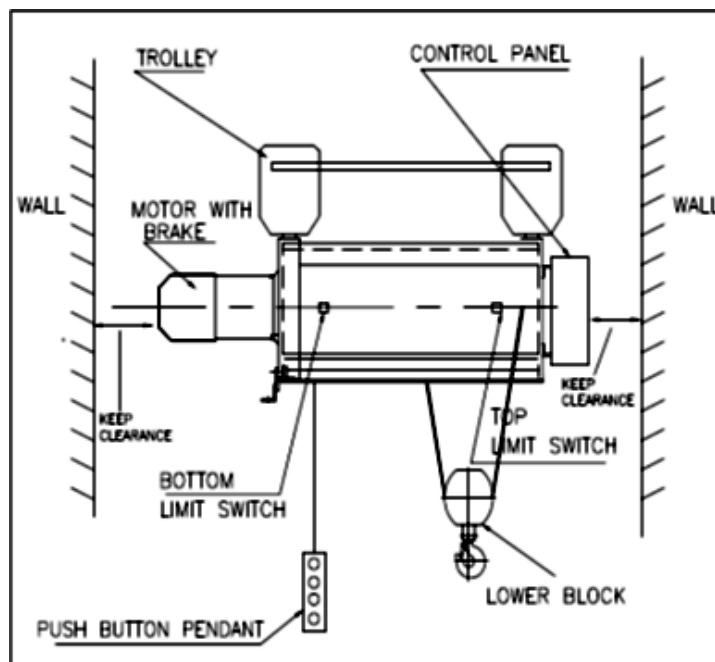

Now, cautiously operate Hoisting push button (see fig. 1) and observe Lower Block movement. In case It is coming down then interchange phase sequence.

Recheck the directions cautiously and operation of Top And Bottom Limit Switches. Adjust limit switches If required.

When everything is set observe movement from top to bottom of lower block without load. Then lift the load by few Cms. And observe that Brake is holding the load.



Now operate cross travel motion and fix proper end stoppers / LS actuation / Buffer on beam so that proper clearance is maintained with motor, Gear box and wall.

TROUBLE SHOOTING

TROUBLE	CAUSE	HOW TO SET RIGHT
Hoist does not start No contractor operates.	Phase sequence wrong or one phase failed or limit switch operated.	Change to phases of main supply. Check with lamp. Check movement of limit switch levers.
Hoist does not start Contractors are working.	Brake not opening or motor defect or overloaded.	Remove brake cover and see movement of brake plate. Check without load
Operation interrupted Chattering of contractors.	Loose connection or wire broken, current collector contact poor.	Tighten all connections. Check wires. Check sitting of shoe & free movement of arm
Push button gets stuck.	Push button sections shifted	Tighten the housing screw.
Braking time too long.	Brake liner is worn.	Adjust brake as per Instructions.
Brake & motor overheats.	Brake not properly opening incorrect air-gap.	Check brake air gap (see the instructions).

Grease		MP3 GREASE HP
Oil for Gear Box		PARTHAN EP 320 (SI-17-C-562)
Oil quantity without creep speed		For hoists with class 'F' insulation; which are exposed to higher temp. or for hoist with 3000 RPM motors use oil PARTHAN EP 320 or equivalent.
SMD 5	12.5 litre	

SAFE OPERATING PROCEDURES FOR OVERHEAD CRANES / HOISTS & SLINGS

DO Not	CAUTIONS	DO
<ul style="list-style-type: none"> • Lift more than rated capacity of Hoist. • Operate Hoist with twisted, kinked or damaged hoist-rope • Operate if rope is not seated in drum or sheave grooves. • Lift unless load slings are centered on hook. • Lift people or travel with people on load. • Make side pulls which misalign rope with hoist. • Operate unless all travel limit devices are functioning. • Lower below point where less than two full wraps of rope remain on hoist drum. • Use upper limit switch to stop hoist limit which is emergency stop only. • Leave operating position with suspended load on hook. • Permit load to contact obstacles. • Exceed recommended duty cycle. • Use Hoist Rope or chain as a sling or as an earthing for welding. • Divert his attention while operating. • Remove or obliterate warning label • Exceed fuse rating. 	<p>WHENEVER LEAVING OR PARKING ANY HOIST OR CRANE</p> <ul style="list-style-type: none"> • Raise all hook to-but not through-limit switches. • Place all controls in off position • Place main power switch in off position. • Make visual check for any dangerous condition & report any defect immediately. • Report to supervisor when Hoist is not in operation. • Take up slacks, than start load slowly. • Keep chains free from twists, knots & knits. • Lift form Center of hooks. Avoid lifting form points. • Distribute load evenly on all legs. • Inspect chain regularly. Remember elongation of links is a sign of overloading. • A sharp edge can cut the lift of your sling. Use blocking padding or a corner saddle. • Remove knots large enough for the load. • Don't jerk loads- jerking may double the stress in your sling. Lift load gradually. <div style="text-align: center;">  <p>NO JERKS</p> <p>HANG SLINGS UP</p> <p>UNCOIL LOOPS STOP KNIKS</p> <p>PROTECT SLINGS ON SHARP CORNERS</p> </div>	<ul style="list-style-type: none"> • Test hoist & travel limit devices at a start of each shift. • Position the Hoist so that lifting appliance is directly over the load. • Take load gently & avoid shock loads. • Ensure the travel path is clear before traveling. • Sound warning single when approaching personnel. • Balancer the loading sling before lifting more than few inches. • Test hoist brakes whenever lifting load approaching rated load capacity. Lift load a few inches & test hoist brakes before making complete lift. • Make visual checks on equipment at reasonable intervals & report the defects immediately. • Use controller to “stop” hoist not limit switch. • Watch for proper rigging on load before lifting. • Know standard hand signals. • Check Lubricants. • Check for proper phasing. • Always anchor outdoor hoists when not attended. • Keep load block safely overhead when not in use.



RECOMMENDED INSPECTION AND MAINTENANCE SCHEDULE

TIME INTERVAL

INSPECTION OR MAINTENANCE

Daily or start of each shift (visual)

- ▶ Check operation of all functional mechanisms including limit switch operation, brakes and control. Report any defect found to properly authorized supervisor & notify the next operator of the defects at the change of the shift.
- ▶ Visually inspect each component of the crane normally used in lifting the load, traveling or lowering the load. This inspection should include, but not be limited to, the items as follow :
 - a. Wire Rope: Inspect for kinks or broken wire or evidence of improper spooling on drum & replace seriously damaged ropes immediately.
 - b. A functional operating mechanisms such as sheaves, drums & brakes.
 - c. Visually inspect entire crane for the sings of damage which might cause unsafe immediately.
 - d. All limit switches of hoisting, Lowering, Cross Travel or swiveling.
 - e. Inspect hooks, lower blocks, and all load bearing components for damage.

1 - 3 Months

- ▶ The result of monthly inspection should be carefully recorded in the suitable log book, in full details, & should be details, & should be dated signed by the inspector.
- ▶ The purpose of the monthly inspection is to find & correct any wear, damage, or defect, which should affect the safe operation of the machine. This should include the items listed under the daily inspection as well as the following:

Inspect the Electrical Controls.

- a. Check hoist gearbox oil level.
- b. Inspect the entire crane or hoist for structural damages.
- c. Inspect for cracked or worn sheave, drums, wheels, rails.
- d. Inspect for worn, cracked or distorted components such as pins, bearing, shaft & gears.
- e. The current collector system should be thoroughly checked & maintained. The contact tips & case of DSL systems should be checked & cleaned regularly.



RECOMMENDED INSPECTION AND MAINTENANCE SCHEDULE

TIME INTERVAL

INSPECTION OR MAINTENANCE

- f. Inspect for excessive wear on brake system parts, linings, pawls, & ratchets. Be sure pawls & ratchets operate correctly, are in good condition & are properly lubricated. Check the conditions of the fire extinguisher, if furnished.
- g. Inspect all motors, controls, & conductor systems which might in any way affect the safety of the machine.
- h. Entire crane or hoist structure, especially surrounding the drive should be thoroughly cleaned.

6 Months

- ▶ Lower Block
- ▶ Rope Guide
- ▶ Lubricate hoist wire rope, Lower block, outboard bearing cartridge at grease fitting.

ANNUALLY

At least annually, the crane hook should be inspected for check by magnetic particle or other suitable crack testing inspection method, to determine that no cracks are discernible. A 15% increase in the throat measurement of hook or a 10% bend in the hook shall be considered cause for replacement.

The above visual & operational checks will take only a few minutes at the beginning of each shift, & are absolutely necessary to ensure safe operation.

*** Complete inspection, disassembly and maintenance required. It is recommended that your HERCULES HOISTS LIMITED repair Station be contacted for this service.**

INSPECTION WHEN REQUIRED :

The third type of inspection concerns individual incidents which apply sudden & unusual stress, or possible damage due to any cause. All such incidents which might affect the safe operation of crane should be followed by an immediate & thorough inspection of the crane, using all necessary non-destructive test methods. All repairs found necessary should be made before the machine is returned to service.

MAINS SPARE PART LIST - 4/2 FALL

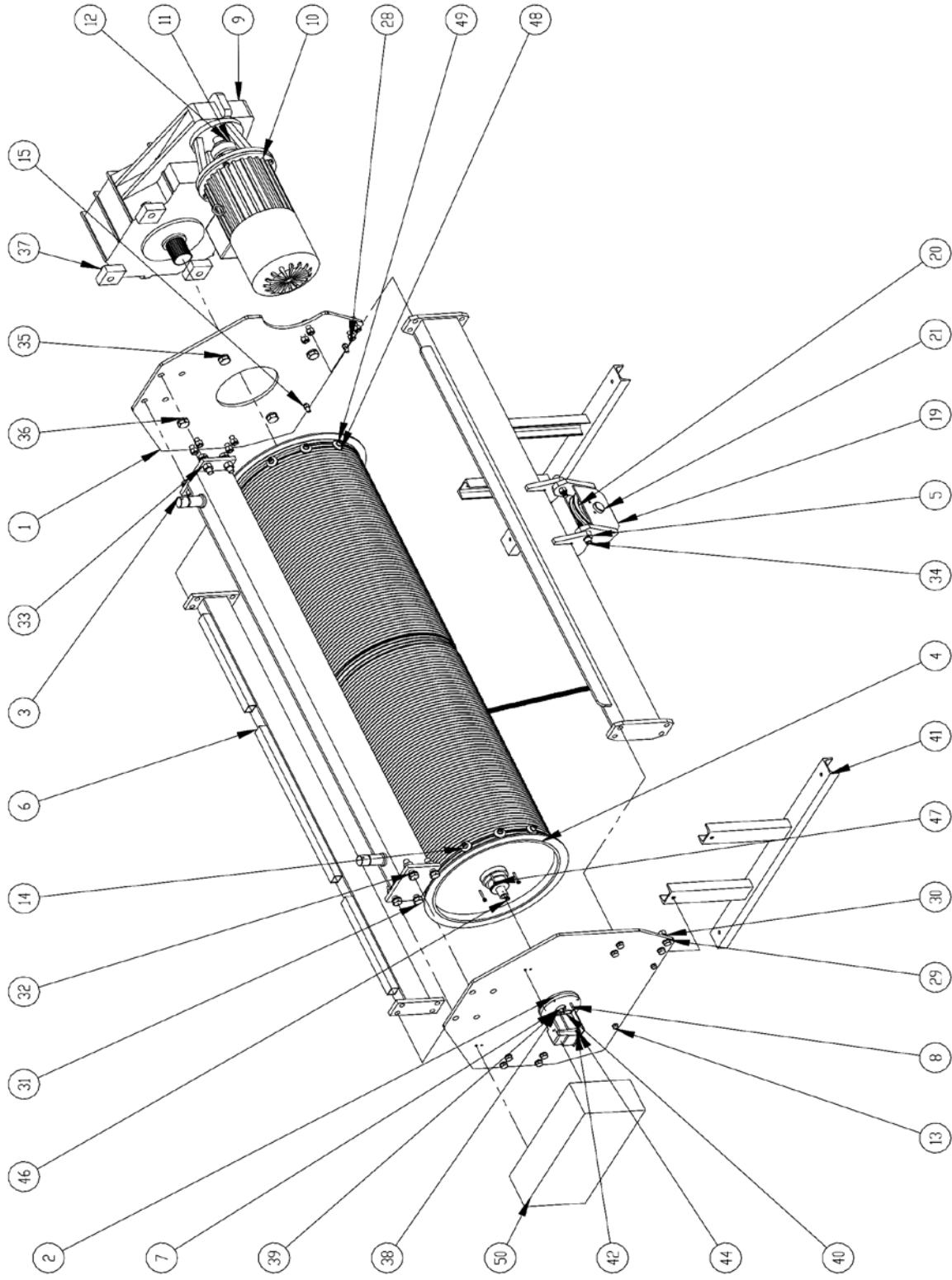

PART NO.	PART CODE	DESCRIPTION	QTY.
1	ZHCA053028A	HOUSING PLATE GEAR BOX SIDE	1
2	ZHCA133030A	HOUSING PLATE ROTARY LIMIT SWITCH SIDE	1
3	ZHBA133060A	TROLLEY SUSPENSION BEAM-BOGIEE (LIFT 20 MTRS)	1
	ZHDA133060A	TROLLEY SUSPENSION BEAM-BOGIEE (LIFT 30 MTRS)	
	ZHFN133060A	TROLLEY SUSPENSION BEAM-BOGIEE (LIFT 50 MTRS)	
	ZHHN133060A	TROLLEY SUSPENSION BEAM-BOGIEE (LIFT 70 MTRS)	
4	ZHBA133001B	DRUM COMPLETE, (LIFT 20 MTRS)	1
	ZHDA133001B	DRUM COMPLETE, (LIFT 30 MTRS)	
	ZHFA133001B	DRUM COMPLETE, (LIFT 50 MTRS)	
	ZHHA133001B	DRUM COMPLETE, (LIFT 70 MTRS)	
5	ZHBA133042A	PULLEY SUSPENSION BEAM (LIFT 20 MTRS)	1
	ZHDA133042A	PULLEY SUSPENSION BEAM (LIFT 30 MTRS)	
	ZHFA133042A	PULLEY SUSPENSION BEAM (LIFT 50 MTRS)	
	ZHHA133042A	PULLEY SUSPENSION BEAM (LIFT 70 MTRS)	
6	ZHBA133041A	DISTANCE BEAM (LIFT 20 MTRS)	1
	ZHDA133041A	DISTANCE BEAM (LIFT 30 MTRS)	
	ZHFA133041A	DISTANCE BEAM (LIFT 50 MTRS)	
	ZHHA133041A	DISTANCE BEAM H7 (LIFT 70 MTRS)	
7	ZBCA833119A	DRUM BEARING COVER	1
8	Y2CA133082AE	ROTARY LIMIT SWITCH MOUNTING BRACKET	1
9	GBM0550LHP0M	GEAR BOX	1
10	XMRP107000*	HOIST MOTOR	1
11	ZHCA823393A	HALF GEAR COUPLING HUB	1
12	ZHCA823392B	HALF GEAR COUPLING HUB	1
13	HBHM1205088	HEX BOLT M12*50	8
14	FLSPWB120000	FLAT SPRING WASHER B12	14
15	HNMM012000YZ	HEX NUT M12	8
16	XBDS0240ELA	HOIST BRAKE	1
17	ASHM08010000	ALLEN SCREW M8*100	3
18	FLSPWB080000	FLAT SPRING WASHER B8	3
19	U5CA133250A	PULLEY HOUSING	1
20	UBCK013026B	GUIDE PULLEY	1
21	UBCK823027B	GUIDE PULLEY AXLE	1
22	UBCK653029A	LOCKING PLATE	1

PART NO.	PART CODE	DESCRIPTION	QTY.
23	BBR06009Z000	BALL BEARING 6009-Z	2
24	UBCA833028A	WASHER	2
25	INCRB0750000	INTERNAL CIRCLIP B75	1
26	FLSPWB100000	FLAT SPRING WASHER B10	2
27	HBHM10016088	HT HEX BOLT M10*16	2
28	HBHM16050088	HT HEX BOLT M16*50	16
29	FLSPWB160000	FLAT SPRING WASHER B16	18
30	HNMM016000YZ	HEX NUT M16	18
31	HBHM20070088	HT HEX BOLT M20*70	8
32	FLSPWB200000	FLAT SPRING WASHER B 20	8
33	HNMM020000YZ	HEX NUT M20	8
34	ASHM16080000	ALLEN SCREW M16X80	2
35	HBHM24080088	HT HEX BOLT M24X80	4
36	FLSPWB240000	FLAT SPRING WASHER B24	4
37	HNMM024000YZ	HEX NUT M24	4
38	BBR062140000	BALL BEARING 6214	1
39	EXCRA0700000	EXTERNAL CIRCLIP A 70	1
40	XMIS000029A	TER LIMIT SWITCH	1
41	ZHCA133191A	PACKING GIRDER	2
42	FLSPWB050000	FLAT SPRING WASHER B-5	6
43	HNMM005000YZ	HEX NUT M5	6
44	HBHM05015088	HEX BOLT 5*15	2
46	HBHM06030088	HT HEX BOLT 6*30	4
47	FLSPWB060000	FLAT SPRING WASHER B6	4
48	PGCA133014A	ROPE CLAMP	6
49	ASHM12040000	ALLEN SCREW (SHCS) M 12*40	6
50	2615601B	CONTROL PANEL	1
51	ASFM05025000	ALLEN SCREW 5*25	4
52	WRF011060370	WIRE ROPE (LIFT 20 MTRS)	100.1 M
	WRF011060370	WIRE ROPE (LIFT 30 MTRS)	140.7 M
	WRF011060370	WIRE ROPE (LIFT 50 MTRS)	221.9 M
	WRF011060370	WIRE ROPE (LIFT 70 MTRS)	295.7 M
Please refer for Motor Part Code ‘*’ Details (BBL, IND)			

ELECTRIC TROLLEY

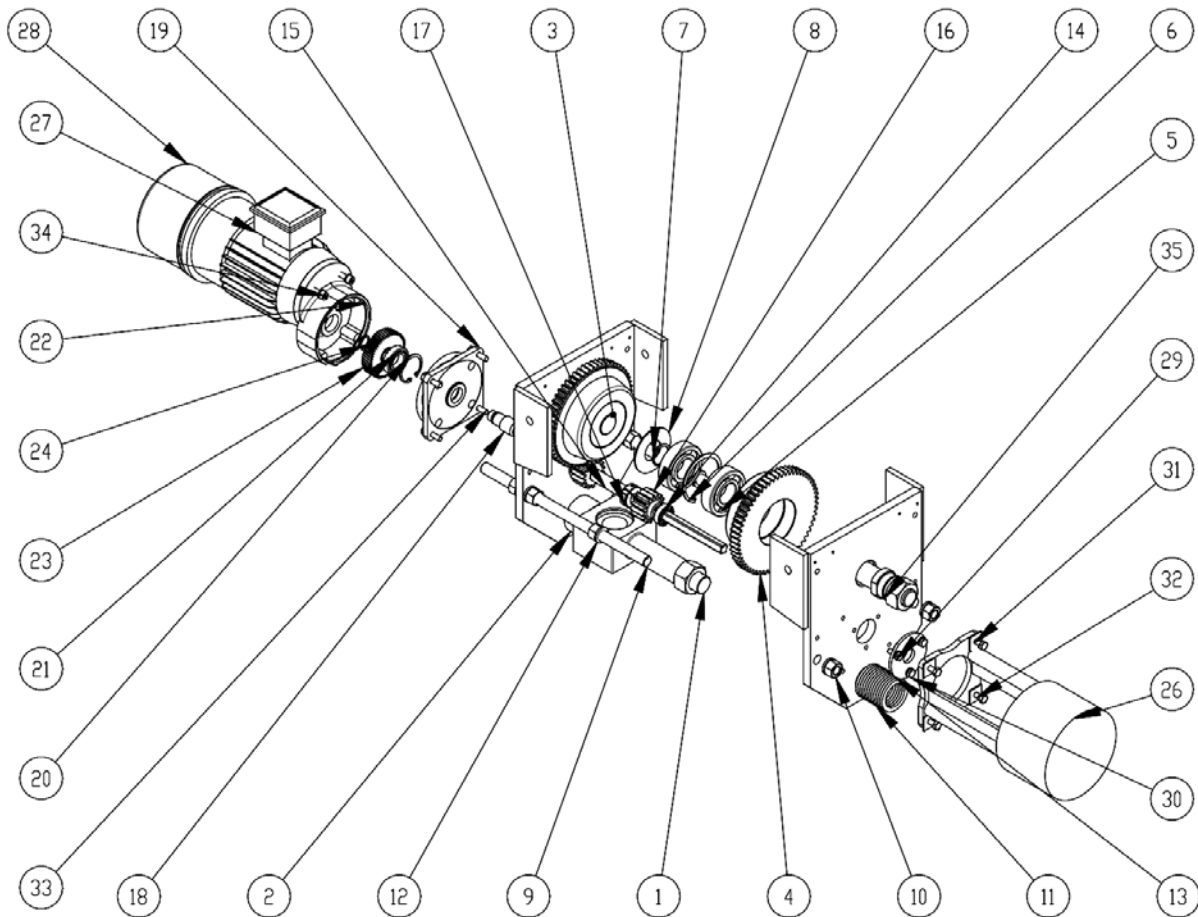

ITEM NO.	PART CODE	DESCRIPTION	QTY.
1	PBCN053064A	LOAD AXLE	1
2	PBCF133001B	GT SIDE PLATE	2
3	PBCF823015B	WHEEL AXLE	2
4	PBCG013013A	GEARED WHEEL	2
5	BBR063070000	BALL BEARING 6307	4
6	INCRB0800000	INTERNAL CIRCLIP B 80	2
7	EXCRA0350000	EXTERNAL CIRCLIP A 35	2
8	PBCF113016A	BALL BEARING COVER	2
9	PCCF833027A	DISTANCE BOLT	2
10	HNMM016000YZ	HEX NUT M16	8
11	PCCF113252A	WASHER	24

ITEM NO.	PART CODE	DESCRIPTION	QTY.
12	FLSPWB160000	FLAT SPRING WASHER B16	8
13	PACF833021B	BEARING HOUSING	1
14	BBR06003ZZ00	BALL BEARING 6003-ZZ/2RS	1
15	PBCF823018C	PINION SHAFT	1
16	PACF823017C	WHEEL PINION	2
17	PACF833020B	CLAMPING WASHER	1
18	PACF813022C	DRIVE SHAFT	1
19	PACF013028B	GEAR BOX COVER	1
20	INCRB0470000	INTERNAL CIRCLIP B47	1
21	BBR060050000	BALL BEARING 6005	1
22	PACF023029B	GEAR BOX HOUSING	1
23	PACF813031B	GEAR WHEEL	1
24	EXCRA0200000	EXTERNAL CIRCLIP A20	1
25	KB0600600180	KEY - BER 6*6*18	1
26	PNC4133069A	COUNTER WEIGTH	1
27	XMRP028000*	TROLLEY MOTOR	1
28	XBAP0060SYT	TROLLEY BRAKE	1
29	FLSPWB080000	FLAT SPRING WASHER B8	9
30	HBHM08016088	HT HEX BOLT M8*16	3
31	SQSPW0080000	SQUARE SPRING WASHER M8	4
32	HBHM08025088	HT HEX BOLT M8*25	4
33	PACF193112B	MODIFIED HT HEX BOLT 8*30	4
34	ASFM08025000	ALLEN SCREW M 8*25	2
35	FLSPWB300000	FLAT SPRING WASHER B30	2
Please refer for Motor Part Code ‘*’ Details (REM/IND/ELE)			

PLAIN TROLLEY

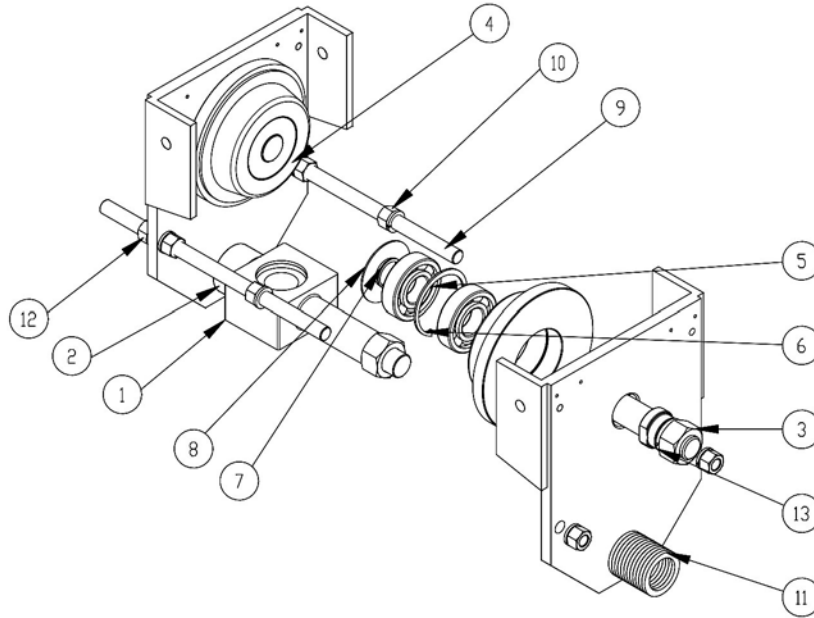

PART NO.	PART CODE	DESCRIPTION	QTY.
1	PBCN053064A	LOAD AXLE	1
2	PBCF133010A	PT SIDE PLATE	3
3	PBCF823015B	WHEEL AXLE	2
4	PBCG013014A	PLAIN WHEEL	2
5	BBR063070000	BALL BEARING 6307	4
6	INCRB0800000	INTERNAL CIRCLIP B 80	2
7	EXCRA0350000	EXTERNAL CIRCLIP A 35	2
8	PBCF113016A	BALL BEARING COVER	2
9	PCCF833027A	DISTANCE BOLT	2
10	HNMM016000YZ	HEX NUT M16	8
11	PCCF113252A	WASHER	24
12	FLSPWB160000	FLAT SPRING WASHER B16	8
13	FLSPWB300000	FLAT SPRING WASHER B30	2

LOWER BLOCK – 4/2 FALL

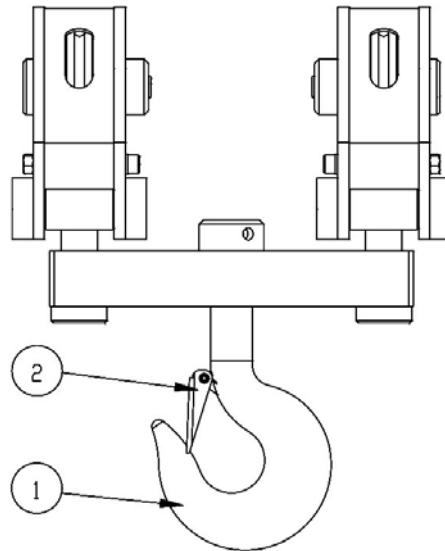

PART NO.	PART CODE	DESCRIPTION	QTY.
1	1470604P	5T LOWER BLOCK ASSLY	
2	UBCK003017A	HOOK WITH SAFETY LATCH ASSLY	1
3	UACK003171A	HOOK LATCH ASSLY	1

TROLLEY BRAKE SPARE PART LIST

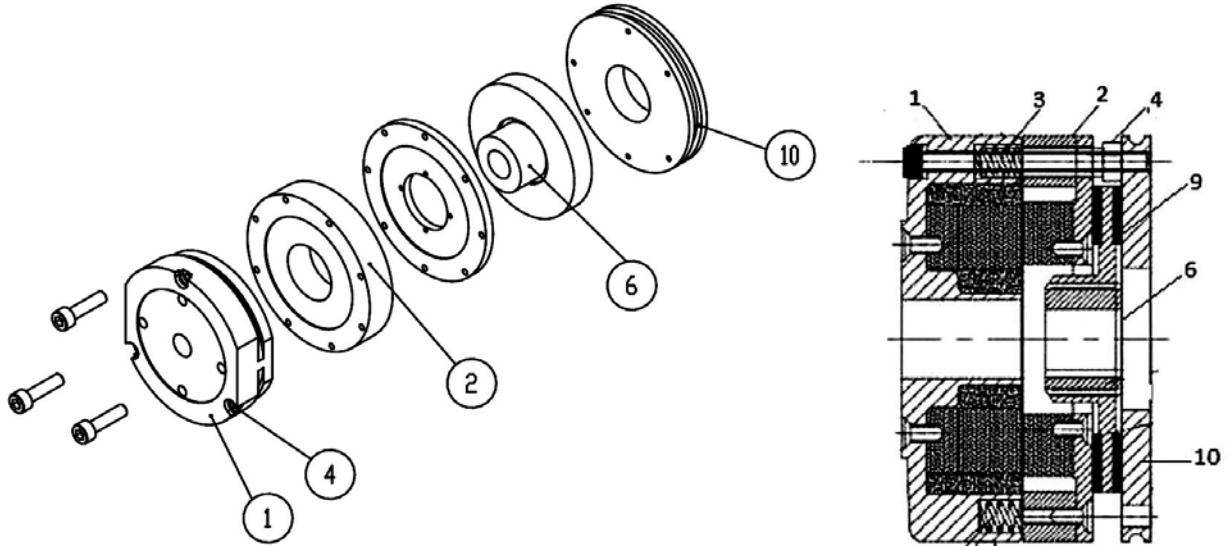

PART NO.	PART CODE	DESCRIPTION
	XBAP0060SYT	MAIN BRAKE
1	XBAP01610SSYT	STATOR
2		ARMATURE ASSEMBLY
3		TUBULAR SPRING EACH SET
4	XBAP87210SSYT	MOUNTING FLANGE ASSLY
6		BRAKE DISC & BRAKE LINER (ROTOR / GEAR HUB)
10	XBAP00510SYT	MOUNTING FLANGE



TROLLEY BRAKE
MAINTENANCE / REPAIR

TROUBLE	POSSIBLE CAUSE	REQUIRED ACTION
Brake does not apply No braking action	No mains voltage. Stator (coil) open.	Check supply voltage. Brake coil resistance to be checked as per the technical data.
	Armature plate Jammed (without moment)	Springs, guide bushes must be checked and overhauled (cleaned properly).
Brake action too slow, insufficient braking effect	Oil or grease on the friction lining	Replace rotor, prevent oil/grease from coming in contact with friction liner.
	Spring are present/broken	Dismantle brake, loosen sleeves insert new springs.
	Brake lining worn-out	Replace rotors (armature plate and flange if very badly worn-out).

To ensure safe & trouble free operation, Spring Loaded Brakes must be checked and maintained at regular intervals. SYTCO Spring Loaded Brakes are wear – resistant and designed for trouble free longer life. The Friction Liners are subject to function -related wear. The Brakes must be checked and readjusted at regular intervals & if necessary, it should be replaced.

PRINCIPLE OF OPERATION : This type of brake consists of stator, Armature, Rotor & Mounting flange. Current is given to stator (coil), the armature plate is attracted to the stator against the spring force thus releasing the rotor. When current is off, strong compression springs push the armature plate back to its position thus clamping the rotor in between armature & mounting flange and providing necessary braking torque.

INSTALLATION : Mounting flange (10) has to be mounted on motor/machine body which should at right angle to the motor/machine shaft as well as centered internally and externally may be with the help of spigot. The hub (6) has to be fitted on shaft with the help of key and axial retainer (circlip) and Rotor (9) on that. Stator (1) with Armature Assembly (2) has to be fitted on the Mounting flange (10) with the help of provided Allen bolt (8) through adjustment Hollow Bushes (4). The air gap should be adjusted by adjustable Hollow Bushes. To reduce air gap, rotate all bushes equally clockwise. Air gap should be within limits as per following table, initially it should be nominal.



Brake size	05	10	20	40	70	90	160	250
Nominal air gap mm	0.2	0.3	0.3	0.3	0.3	0.4	0.5	0.5
Maximum air gap mm	0.5	0.7	0.7	0.7	0.8	1.0	1.0	1.0

MAINTANENCE : SYTCO Fail Safe Brakes are almost maintenance free. For this periodicity depends on application to application, operating frequency, system inertia to be stopped etc. air gap can be adjusted by rotating adjustable Hollow Bushes to reduce air gap. Rotate all bushes anti-clockwise and check from all sides by filler gauge and vice-versa.

TYPICAL CASES OF WRONG FITMENT

Typical case of uneven air gap in brake disc: This should be noticed and avoided during preventive maintenance.



Typical case of stator resting bolt head, which will restrict the stator lateral movement of brake disc: This should be noticed and avoided during preventive maintenance.



Typical case of stator fitting, the half-moon slot is to clear the bolt head, brake housing fitment wrong, which will obstruct the stator lateral movement of brake disc: This should be noticed and avoided during preventive maintenance.



TYPICAL CASES OF WRONG WIRING

The RYB colour code of connecting cables to be maintained and wiring connections to be followed accordingly. The supply voltage is 415+/-10% for all AC brakes. The power supply fluctuations will have effect on brake coil first than motor as coil are more sensitive than motor windings.

HOIST BRAKE SPARE PART LIST

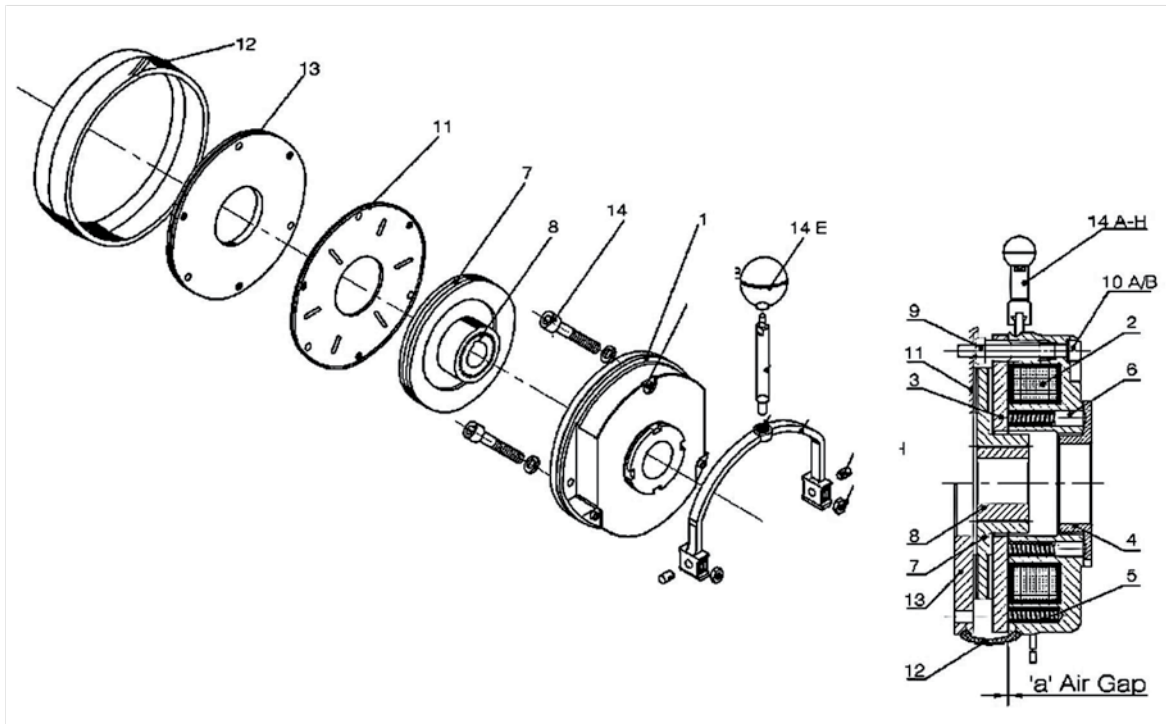

PART NO.	PART CODE	DESCRIPTION
	XBDS0240ELA	MAIN BRAKE
1	XBDS0242ELA	STATOR ARMATURE ASSEMBLY
2		STATOR
3		ARMATURE PLATE
14		HAND RELEASE ASSEMBLY
4	XBDS0247ELA	TARQUE ADJUSTMENT RING
5		COMPRESSION SPRING
6		COMPRESSION PARTS
7		ROTOR
8		HUB
9		ADJUSTMENT TUBE
10	XBDS0250ELA	MOUNTING BOLT & WASHER
11		FRICITION PLATE
12		RUBBER SEAL
13		MOUNTING FLANGE



HOIST BRAKE

SAFETY PRECAUTIONS

1. To prevent electrical mishaps be sure to disconnect the power to the brake from its source before attempting to service or repair.
2. Look down or secure any load hold by this brake prior to service or repair
3. If this brake has been supplied with a manual hand release, do not override the brake by securing the hand release in an open position
4. Do not operate brake in atmospheres with explosive gases and dusts or corrosive substances. This brake can operate in non explosive dust or with optional seal in water splash and Almaden Atmospheres.
5. When storing or installing the friction rotor, ensure that oil or grease is kept from the friction material surface.

Air gap Hand Release Value

SIZE	06	08	10	12	14	16	18	20	25
a' MIN.	0.2	0.2	0.2	0.3	0.3	0.3	0.4	0.4	0.5
a' MAX.	0.5	0.6	0.6	1.0	1.1	1.4	1.4	1.6	2.2

WIRING DIAGRAM

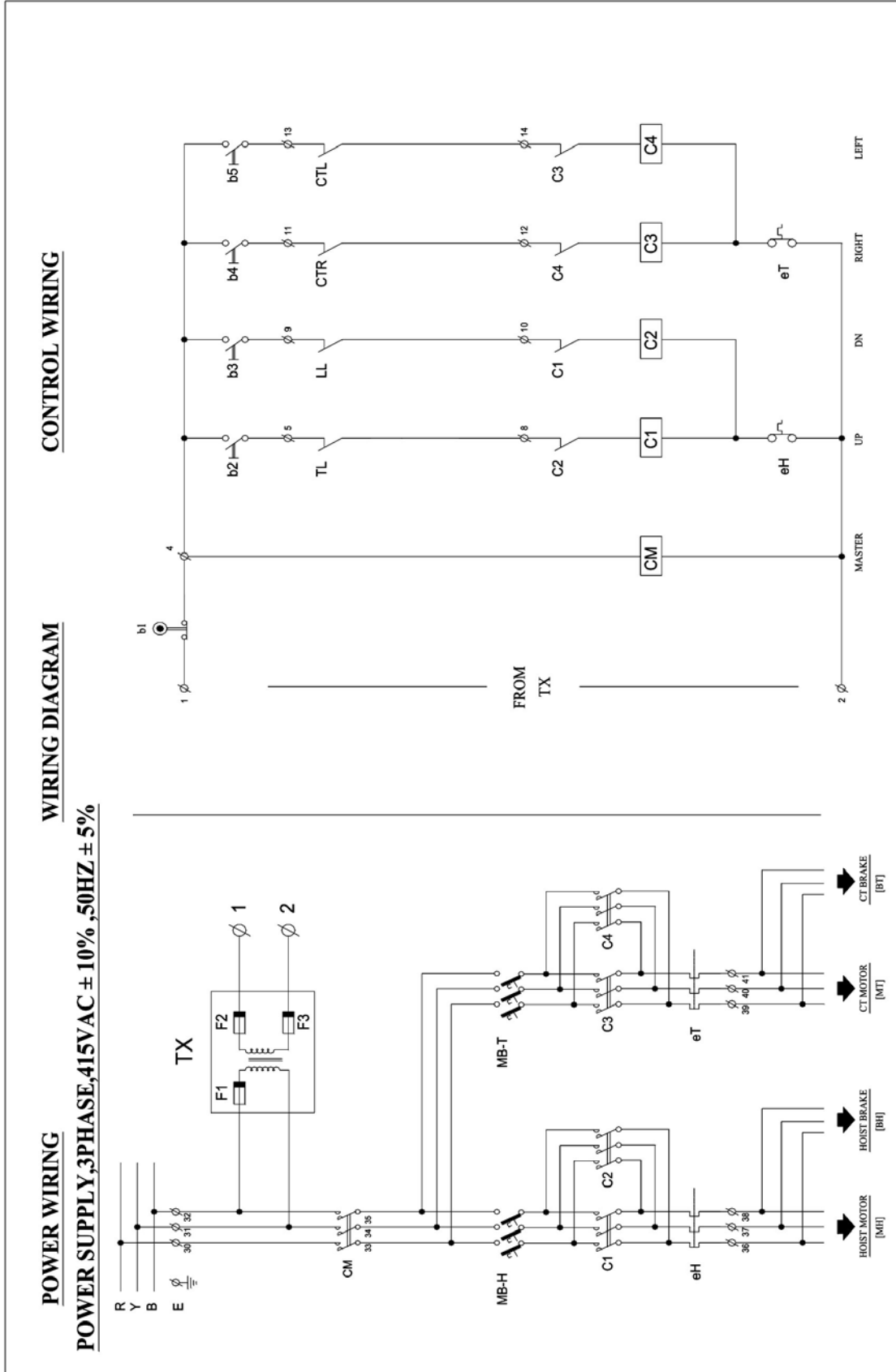

ELECTRICAL SPARE PARTS – ET

ITEM CODE	DESCRIPTION	QTY
XCPP124000A	Enclosure for Baseplate XCPP124001A Size 560X260X150 mm	1
XCPP124001A	Baseplate for Enclosure XCPP124000A Size 490X220X2 mm	1
XCTP0002AVA	Avetronics/Prince Make Control Transformer Primary 415VAC ± 5%, ± 10% & Secondary 110VAC,100VA	1
XMCP0080MDA	Schneider Make MCB 3P 32A Cat No A9N3P32D - Hoist Motor	1
XMCP0120MDA	Schneider Make MCB 3P 4A Cat No A9N3P04D - ET Motor	1
XACP0140SMA	Schneider Make Contactor 32A/110VAC Cat No LC1D32 F7 - Master, Hoist Motor	3
XACP0850TMA	Schneider Make Contactor 9A/110VAC Cat No LC1D09 F7 - ET Motor	2
ELTEMP00005	SCHNEIDER MAKE OVERLOAD RELAY 12-18A CAT NO LRD21	1
XORE0290TMA	SCHNEIDER MAKE OVERLOAD RELAY 1.6-2.5A CAT NO LRD07	1
XRFE0050ELA	Solid State Rectifier 440VAC / 190VDC, Rating 2A	
XLSP0064SLZ	GIOVENZANA MAKE ROTARY GEAR LIMIT SWITCH FGR102002 1 :100 RATIO 2 MICRO (LIFT 20, 30M)	1
XLSP0065SLZ	GIOVENZANA MAKE ROTARY GEAR LIMIT SWITCH FGR102002 1 :200 RATIO 2 MICRO (LIFT 50, 70M)	
XLSP0090SLZ	Indef Make Limit Switch in Oil Tight Housing, Normal Roller Lever 1NO+1NC, Normal Action, Rating 10A/500V Cat No.SL603N	2
XPBP0003HHL	Indef Make 5 Way Pendant (Emergency Stop, Hoist/ Low Single Speed, Right/Left Single Speed)	1

ELECTRICAL SPARE PARTS – GT/PT

ITEM CODE	DESCRIPTION	QTY
XXCPP123000A	Enclosure for Baseplate XCPP123001A Size 440X260X150 mm	1
XCPP123001A	Baseplate for Enclosure XCPP123000A Size 370X220X2 mm	1
XCTP0002AVA	Avetronics/Prince Make Control Transformer Primary 415VAC ± 5%, ± 10% & Secondary 110VAC,100VA	1
XMCP0080MDA	Schneider Make MCB 3P 32A Cat No A9N3P32D - Hoist Motor	1
XACP0140SMA	Schneider Make Contactor 32A/110VAC Cat No LC1D32 F7 - Master, Hoist Motor	3
ELTEMP00005	SCHNEIDER MAKE OVERLOAD RELAY 12-18A CAT NO LRD21	1
XRFE0050ELA	Solid State Rectifier 440VAC / 190VDC, Rating 2A	
XLSP0064SLZ	GIOVENZANA MAKE ROTARY GEAR LIMIT SWITCH FGR102002 1 :100 RATIO 2 MICRO (LIFT 20, 30M)	1
XLSP0065SLZ	GIOVENZANA MAKE ROTARY GEAR LIMIT SWITCH FGR102002 1 :200 RATIO 2 MICRO (LIFT 50, 70M)	
XPBP0001HHL	Indef Make 3 Way Pendant (Emergency Stop, Hoist/ Low Single Speed)	1

MAINTENANCE AND HANDLING

Lubrication

Wire Rope:

- ▶ For proper performance the Wire Rope must be maintained in a clean and well lubricated condition.
- ▶ The rope should be lubricated every 3 months (more frequently for heavier usage or severe conditions).
- ▶ To lubricate the rope, first remove any dirt, grime, moisture or other accumulations of contaminates. Then coat the Wire Rope with ENKLO 68 (M1-18-J-754) oil or equivalent. Ensure that the lubricant is applied to the entire surface of the rope over its entire length.
- ▶ For dusty environments, dry lubricants are suggested.
- ▶ For conditions not permitting lubricant to fall off the wire rope, consider using non-dripping motorcycle drive chain lubricant.

Wire Rope Drum, Hook Block and Sheaves:

- ▶ The drum, hook block and sheaves should be lubricated every 3 months (more frequently for heavier usage or severe conditions).
- ▶ Lubricate the Drum, Hook Block and Sheaves with ENKLO 68 (M1-18-J-754) or MP GREASE 3 (SI-18-M-211) grease.
- ▶ For dusty environments, dry lubricants are suggested.
- ▶ For conditions not permitting lubricant to fall off the drum, hook block and sheaves, consider using non-dripping motorcycle drive chain lubricant.

Trolley Wheels and Gears:

- ▶ The Trolley Wheels and Gears should be lubricated every 3 months (more frequently for heavier usage or severe conditions).
- ▶ Lubricate the Trolley Wheels and Gears with MP GREASE 3 (SI-18-M-211) grease.
- ▶ For dusty environments, dry lubricants are suggested.
- ▶ For conditions not permitting lubricant to fall off the trolley wheels and gears, consider using non-dripping motorcycle drive chain lubricant.

Hoist and Trolley Gearboxes – The hoist and trolley gearboxes are lubricated for life and should not need any lubricant replacement.



HERCULES HOISTS LIMITED

CAUTION

WARRANTY VALID ONLY IF INSTALLATION CERTIFIED BY HHL AUTHORISED PERSONNEL

DOWNLOAD genuine indef APP TO REGISTER YOUR HOISTS & CERTIFICATION REQUEST

Please ask for a copy of our on-line certification report to ensure your warranty
Register your Company & you purchased Product on our App and get 3 (three) month additional warranty

HERCULES HOISTS LIMITED

SERVICE CONTACT : +91 8669994119

service@indef.com - ANYTIME

www.indef.com/service - ANYTIME

Issue Date	Revision	Revision summary
01.08.2020	R0	-
07.02.2022	R1	Part Codes & Service No. Changed

HERCULES HOISTS LIMITED

C.T.S. No.43/2B, 43/5, 45/2, Near Naik Navre Chemicals
At Village - Dhamani, Tal. - Khalapur, Dist. - Raigad, Khopoli - 410202 (M.S.)
E-mail : csga@indef.com
Tel. 02192-662502/503/555 Fax : 02192-662504

501-504, 5th Floor , Shelton Cubix, Plot No. 87, CBD Belapur,
Navi Mumbai 400 614. Maharashtra, INDIA
P: +91 22-45417300

www.indef.com