

# **OPERATING & MAINTENANCE INSTRUCTION MANUAL WITH SPARE PART LIST**

(Guarantee will be void if not used as instructed in this manual)

## **INDEF M ET & STIERv MONORAIL TRAVELLING TROLLEYS**

Capacity: 1T-15T



## INDEX

1. General Safety	3
2. Installation and Commissioning	4
3. Spare Parts & Maintenance	6
4. Spare Parts for trolley (Push / Hard Geared Type)	9
5. Spare Parts for Electric Trolley	12
6. Spare Parts for Motor with Brake (Optional) (Pethe Brake)	15
7. Wiring Diagram	19
8. Spare Parts for 5T GT	20
9. Spare Parts for 10T GT	23
10. Spare Parts for 15T/20T GT	26

## **1. GENERAL SAFETY**

### **1.1 INTRODUCTION**

HERCULES HOISTS LIMITED has taken all practical care in the design and manufacture of its “Indef” brand products to ensure that they are safely constructed. However, the use of material handling equipment’s presents hazards, which cannot be prevented by mechanical means and are related to the manner in which the material handling equipment’s are used.

Operators must be competent, physically and mentally fit and properly trained in the safe operation of material handling equipment’s and the handling of loads.

Safety Instructions must form part of the safety rules for any plant where any material handling equipment is used, serviced or repaired.

It is impossible to foresee all operating conditions and it must remain the responsibility of the operator to anticipate and avoid any unsafe conditions not covered in detail in this manual.

No machine is entirely safe unless it properly maintained. It is important to practice a program of periodic inspection and preventative maintenance.

The material handling equipment’s detailed in this manual, are designed to transport loads using the equipment supplied for the specific purpose. The equipment must not be used for any other purposes. Lifting / transporting human beings are strictly prohibited.

The safety information must be read and understood by all personnel before commencing operation or maintenance.

### **1.2 SAFE WORKING LOAD**

The safe workings load is that load indicated on capacity plate of the unit. This is the maximum load that may safely be handled. Under no circumstances should a load greater than the SWL be suspended to the trolley.

### **1.3 ELECTRICAL SAFETY**

1. Ensure proper earthing.
2. Isolate power supply before opening the control panel.
3. All electrical related work should be carried out by trained and qualified person.
4. Check and tighten the power & control wiring if loose to avoid loose connections.

## 2. INSTALLATION AND COMMISSIONING

### 2.1 PRE-INSTALLATION CHECKS

1. Check for transit damage.
2. Check that all fasteners and joints are tight and secure.
3. Check the capacity of the unit.

### 2. 2.2 TRAVELLING TROLLEY

The runway beam or girder should be of correct size, of adequate strength with an even running surface. The running surface should be levelled properly. Where it is possible to install the unit onto the beam without dismantling the trolley, the trolley should be positioned on the beam and end stops fitted to both ends of the beam.

Where it is necessary to dismantle the trolley in order to install the trolley on the beam, the trolley has to be set to the correct track width. Ensure that adequate end stops are fitted to the runway beam.

### 2. 2.3 TROLLEY ADJUSTMENT

1. Measure the beam width to be used and add a nominal 3mm to 4mm to this width, for running clearance (1½mm to 2mm each side).
2. Remove trolley cross bolt nuts.
3. By transferring the required number and thickness of adjusting washers from the outside to the inside of the side plates, or vice versa, as required, the necessary setting can be achieved. There must always be at least one adjusting washer outside the side-plates on each cross bolt, under each of the four large nuts.
4. Ensure that, between the side plates, the adjusting washers are equally disposed on both sides of the yoke or suspension plate(s) and also equally disposed between both cross bolts. This ensures the yoke or suspension plate(s) remain central and lie square to the side plates and parallel to the plane of the beam.
5. After re-fitting the yoke or suspension plate(s), distance tubes, and required number of adjusting washers between the side plates, replace all remaining washers on the cross bolts outside the side-plates.
6. If the trolley has hand-gear travel, it may be necessary to offset the cross bolts by placing the remaining washers at one end of the cross bolts to gain clearance between the hand chain and the ends of the cross bolts. Tighten the main cross bolt nuts firmly, ensuring that runners are correctly aligned.
7. In case of hand geared-trolley anti tipping stops are provided for preventing over tilting of trolley. The stop is to be adjusted as under at the time of installation of trolley :



- A) Unlock two nuts provided at the center of trolley side plate.
- B) Move the stopper up or down in slot as required so that distance between bottom of the I-beam and top surface of stopper will be @ 2mm.
- C) Tighten the two nuts properly so as to hold stopper in position.

## 2. 2.4 COMMISSIONING

All units are tested, in accordance with Statutory requirements, and a test Certificate is supplied.

On completion of installation, before the hoist is put into regular service, the following procedure should be carried out.

1. Check that all joints and fasteners are tight and secure.
2. Operate the equipment with both, “no load” and “full load” and check that the operation is smooth at all times.
3. Travelling units - run throughout the full extent of the runway, ensuring adequate clearance at all times and end stoppers are correctly positioned.

## 2. 2.5 ROUTINE EXAMINATION

The trolley should be regularly inspected for damage and wear and to ensure that it is operating smoothly. Where the trolley is used infrequently, a visual check should be made of the trolley each time it is used.

The following is a guide to routine checks, which should be carried out on a trolley, which is used in normal operation conditions. Where a trolley is used or stored outdoors or in corrosive or abrasive conditions, inspection and lubrication must be attended to more frequently.

## 2.6 INSPECTION CHECK-LIST

### Trolley

Side Plates	Inspect visually	Must not be cracked or damaged. Cross bolt holes must not be elongated.
Cross Bolts	Inspect visually	Must not be bent
Trolley Runners	Inspect visually	Must not be cracked, damaged or worn and must rotate freely.
Gearing (traverse shaft and geared runners where fitted)	Inspect visually	Gear teeth must not be chipped, flattened, deformed or damaged. Traverse shaft must be secure and not bent or deformed. There must be no movement or play between the shaft and the hand chain wheel.
Hand Chain Wheel (Geared Travel only)	Inspect visually	Wheel must not be cracked or damaged. Chain pockets must not be deformed.



### 3 . SPARE PARTS

To ensure compatibility of parts, it is recommended that spares be obtained from Authorized dealers of INDEF. When ordering spare parts, quote the serial number, the unit capacity, the part number, description, Drawing number and quantity required.

### 3.1 MAINTENANCE

Statutory regulations require that the trollies should be inspected and certified at regular intervals by a competent person. This is a safety measure, and to fulfill both this requirement and to obtain the most efficient and reliable operation, the trolley should be regularly serviced and maintained.

#### LUBRICATION

Lubrication must be carried out regularly, at the intervals specified and when the hoist is dismantled for overhaul or repair.

In high duty use or in abrasive, corrosive or hot environments, the hoist may require more frequent attention and frequencies given below must be regarded as a minimum.

PART	LUBRICANT	APPLICATION	FREQUENCY
<b>TROLLEY</b>	<b>HP</b>		
Runner Bearings required	Grease	Pressure packed during	No re-lubrication manufacture.
Traverse Shaft (Geared travel only)	Tisona - M2	Liberally smear the bush ends where these mate with another surface.	Re-lubricate only after stripping the trolley for the replacement of parts.
Spur Gearing (Geared travel only)	Tisona - M2	Clean all gears and apply fresh lubricant ensuring full cover, without allowing any lubricant onto the runner treads.	Every 6 months
Gear Box (Electric Trolley)	Grease	Apply on gear and pinion	Every 6 months

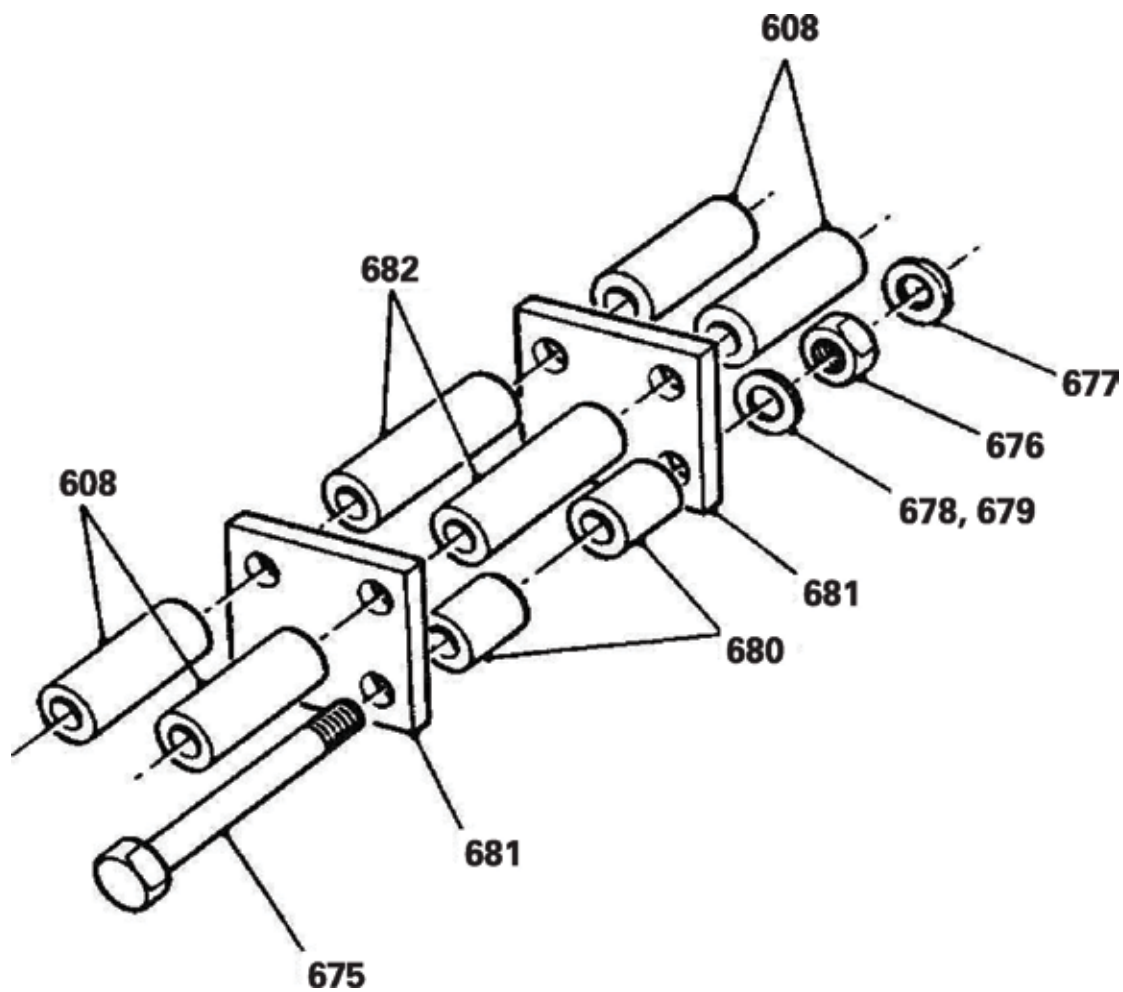

**Figure : 1 Additional Items for Range 3 Trolleys (Optional)**

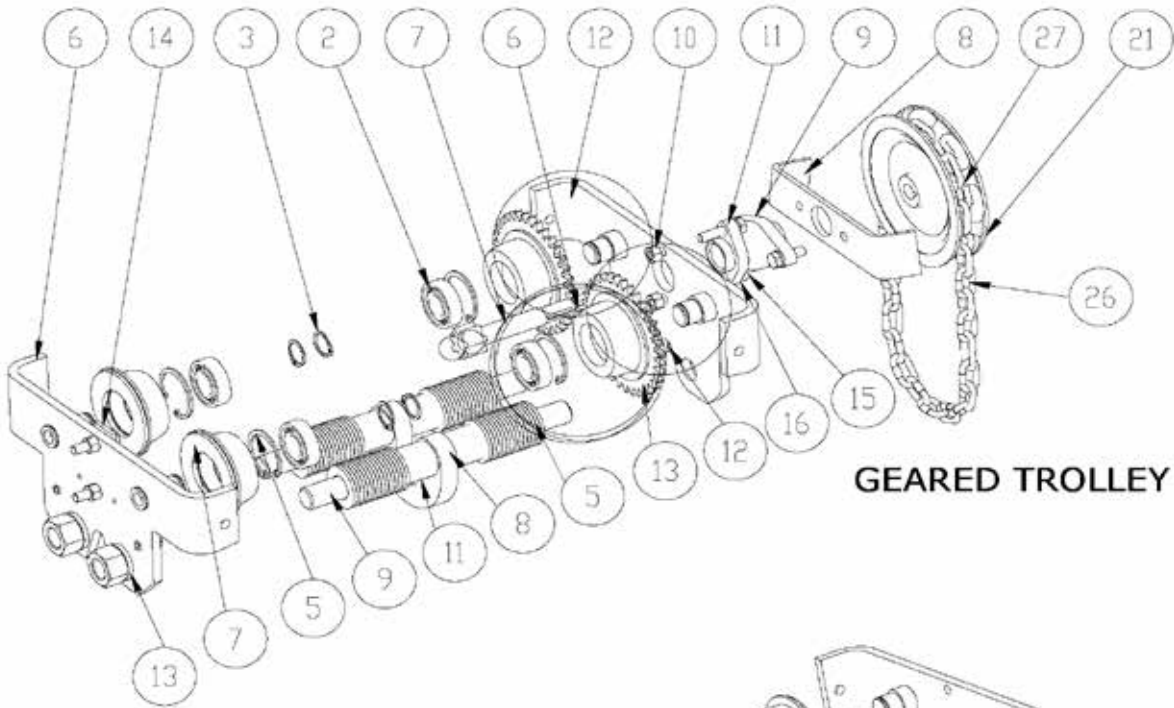

**GEARED TROLLEY**

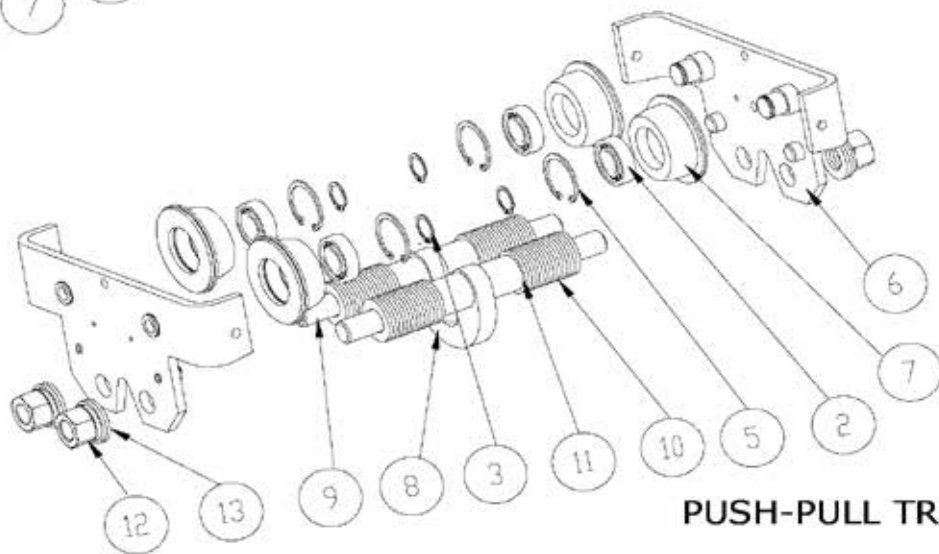

**PUSH-PULL TROLLEY**



**Figure : 2 Trolley Arrangement**

ITEM NO.	DESCRIPTION	QTY.	PART NUMBER	
			1T	2T/3T
1	SIDE PLATE WITH PINS GEARED SIDE	1	RDCM002010B	RFCM002010B
2	BALL BEARING	4	BBR06004ZZ00	BBR06205RS00
3	EXTERNAL CIRCLIP	4	EXCRA0200000	EXCRA0250000
4	GEARED RUNNER/SPUR ASSLY	2	RDCM003108B	RFCM003108C
5	INTERNAL CIRCLIP	4	INCRB04200000	INCRB0520000
6	SIDE PLATE WITH PINS UNGRD SIDE	1	RDCM002001B	RFCM002001C
7	RUNNER PUSH-PULL	2	RCCM823104B	RECM823104B
8	HOOK SUSPENSION PLATE	1	RCCH053009B	RECH053009A
9	CROSS BOLT RANGE 1	2	RCAM833201A	REAM833201B
	RANGE 2	2	RCBM833301A	REBM833301A
	RANGE 3	2	RCDM833401A	REDM833401A
10	WASHER	64	RCCM833205A	RECM833205A
11	DISTANCE TUBE RANGE 1	4	RCDM873204A	REAM873204A
	RANGE 2	8	RCDM873204A	REAM873204A
	RANGE 3	16	RCDM873204A	REAM873204A
12	HEX NUT	4	HNMM020000YZ	HNMM0240000Z
13	FLAT SPRING WASHER	4	FLSPWB200000	FLSPWB240000
14	ANTI- TIPPING STOP	1	RDCM313019A	RDCM313019A
15	HEX BOLT	4	HBHM08035088	HBHM08035088
16	FLAT SPRING WASHER	6	FLSPWB080000	FLSPWB080000
17	HEX NUT	6	HNMM0080000YZ	HNMM0080000YZ
18	TRAVERSE SHAFT	1	RBCT823903C	RBCT823903C
19	TRAVERSE SLEEVE ASSLY	1	RBCT002009B	RBCT002009B
20	HAND CHAIN GUARD	1	RBCT313904A	RBCT313904A
21	HAND CHAIN WHEEL	1	RBCT013901B	RBCT013901B
22	KEY - BER	1	KB0400400200	KB0400400200
23	HT HEX BOLT	2	HBHM08025088	HBHM08025088



ITEM NO.	DESCRIPTION	QTY.	PART NUMBER	
			1T	2T/3T
24	FLAT SPRING WASHER	1	FLSPWB120000	FLSPWB120000
25	HEX NUT	1	HNMM012000YZ	HNMM012000YZ
26	HAND CHAIN 5 * 22.5	AS PER REQ	CHHYN0502253	CHHYN0502253
27	JOINING LINK	1	CHJL050225YZ	CHJL050225YZ

**TROLLEY SPARE PARTS (SPARK PROOF GEARED TROLLEY)**

Part No.	Description Capacity in Kgs.	Qty.	Drawing Number	
			1000	2000/3000
627	GEARED WHEEL	2	RUCM063109B	RWCM063108B
628	PLAIN WHEEL	2	RPCM063105B	RVCM063106B
630	GEAR SIDE PLATE	1	RUCM002010A	RWCM002010B
631	UNGEARED SIDE PLATE	1	RUCM002001A	RWCM002001B
650	HAND CHAIN GUARD	1	RUCT063904A	RUCT063904A
651	TRAVERSE SHAFT	1	RBCT823903C	RBCT823903C
652	HAND CHAIN WHEEL	1	RUCT063901A	RUCT063901A

**ELECTRIC TROLLEY**

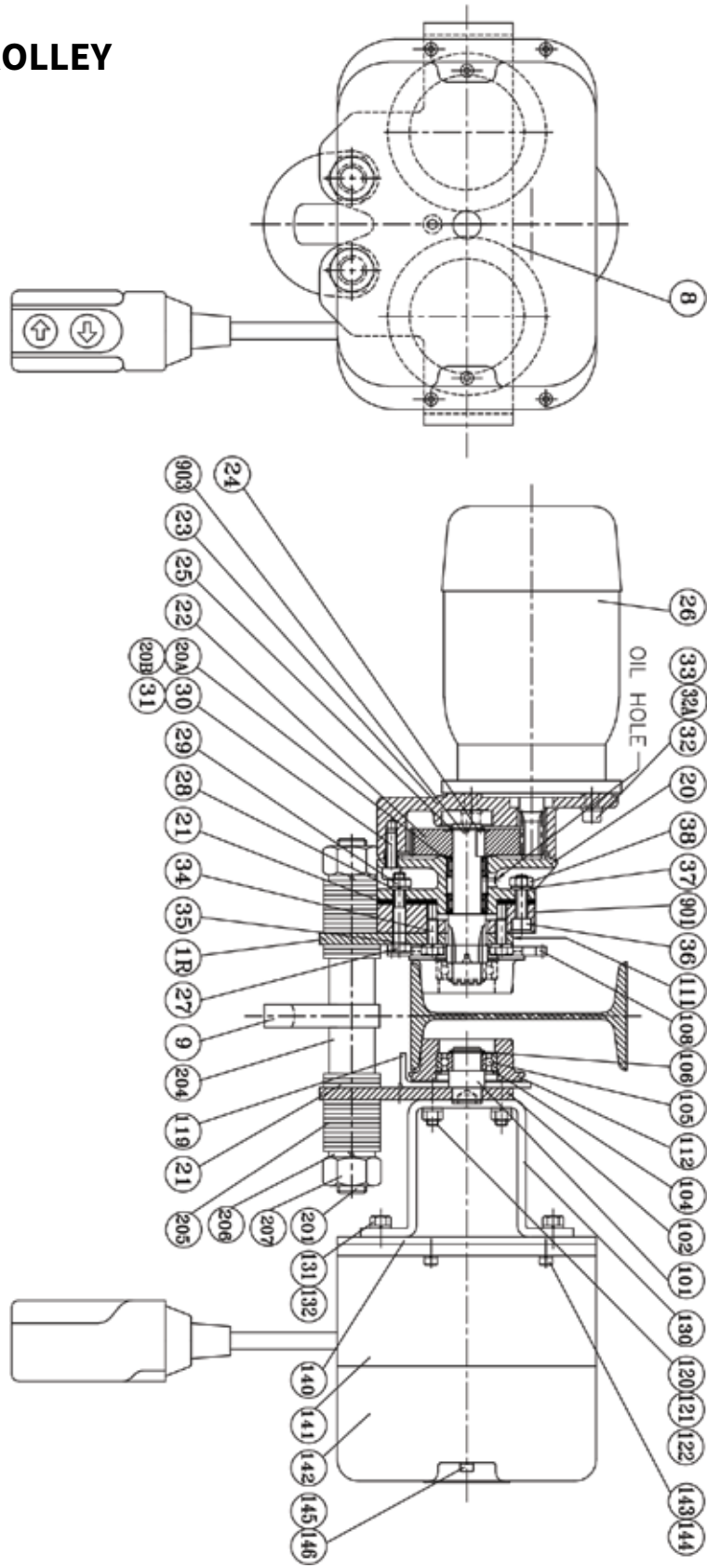

### 5. SPARE PARTS FOR ELECTRIC TROLLEY

Part No.	Description	Qty	Drawing Number	
			1000	3000
	Capacity in Kgs.		1000	3000
1R	Side plate with pins	1	RDCM002001B	RFCM002001C
1OR	Side plate with pins	1	RGCM002010B	RNCM003001B
104	Runner (Plain)	2	RCCM823104B	RECM823104B
105	Bearing	2	BBRO6004RS00	BBRO6205RS00
106	Circlip	2	EXCRA0200000	EXCRA0250000
119	Anti tipping stop Geared	1	RDCM313019A	RDCM313019A
120	Bolt	2	HBHM08035088	HBHM08035088
121	Nut	2	HNMM0800000Z	HNMM0800000Z
122	Washer	2	FLSPWB080000	FLSPWB080000
112	Circlip	2	INCRB04200000	INCRB05200000
108	Geared Runner	2	RDCM003108B	RFCM003108C
109	Bearing	2	BBRO6004RS00	BBRO6205RS00
110	Circlip	2	EXCRA0200000	EXCRA0250000
112	Circlip	2	INCRB04200000	INCRB0520000
901	Adaptor Plate	1	RGCT053901A	RGCT053901A
903	Pinion	1	RGCT813903C	RGCT813903C
20	Bearing Block	1	MCCM023020C	MCCM023020C
20A	Bush	2	MCCM033020A	MCCM033020A
21	Spacer	2	MBCM113021A	
22	Gear Wheel	1	PACF813031B	PACF813031B
23	Gear Box Housing	1	PACF023029B	PACF023029B
26	Motor (10mpm)	1	XMRP039000*	XMRP039000*
26	Brake	1	XBAP0060SYT	XBAP0060SYT
24	Key	1	K00600600180	K00600600180
25	Circlip	1	EXCRA0200000	EXCRA0200000
27	Bolt	2	HBHM08025088	HBHM08025088
28	Washer	3	FLSPWB080000	FLSPWB080000
29	Nut	3	HNMM0800000	HNMM0800000
30	Bolt	4	HBMM08025046	HBMM08025046
31	Washer	4	FLSPWB080000	FLSPWB80000

Part No.	Description	Qty	Drawing Number	
	Capacity in Kgs.		1000	3000
32	Screw	2	ASFM08025000	ASFM08025000
32A	Bolt	2	HBHM08025088	HBHM08025088
33	Washer	4	FLSPWB080000	FLSPWB080000
34	Bolt	2	HBHM08020088	HBHM08020088
35	Washer	2	FSLPWB080000	FLSPWB080000
36	Bolt	1	HBHM08025088	HBHM08025088
37	Washer	1	FLSPWB080000	FLSPWB080000
38	Nut	1	HNMM00800000	HNMM00800000
130	Bracket		RGCM132131A	RGCM132131A
131	Bolt	2	HBMM08012046	HBMM08012046
132	Spacer	2	FLSPWB080000	FLSPWB080000
140	Counter Plate	1	UECE653003A	UECE653003A
141	Panel Housing	1	UECE043001A	UECE043001A
142	Panel Cover	1	UECE043002A	UECE043002A
143	Screw	4	ASFM05012000	ASFM05012000
144	Washer	4	FLSPWB050000	FLSPWB050000
145	Screw	2	ASHM06080000	ASHM06080000
146	Washer	2	FLSPWB060000	FLSPWB060000
<b>Please refer for Motor Part Code ‘*’ Details (REM/IND/ELE)</b>				

**INDEF M ET SPARE FOR RANGE 1**

PART NO	DESCRIPTION	DRAWING NO 1000 KG	QTY	DRAWING NO 3000 KG	QTY
201	CROSS NUT	RCAM833201A	2	REAM833201B	2
204	DISTANCE TUBE	RCDM873204A	4	REAM873204A	4
205	WASHER	RCCM833205A	72	RECM833205A	56
206	WASHER	FLSPWB200000	4	FLSPWB240000	4
207	NUT	HNMMO20000YZ	4	HNMMO24000YZ	4
9	HOOK SUSPENSION	RCCH053009B	1	RECH053009B	1

**INDEF M ET SPARE FOR RANGE 2**

PART NO	DESCRIPTION	DRAWING NO 1000 KG	QTY	DRAWING NO 3000 KG	QTY
201	CROSS NUT	RCDM833401A	2	REBM833301A	2
204	DISTANCE TUBE	RCDM873204A	8	REAM873204A	8
205	WASHER	RCCM833205A	80	RECM833205A	52
206	WASHER	FLSPWB200000	4	FLSPWB240000	4
207	NUT	HNMMO20000YZ	4	HNMMO24000YZ	4
9	HOOK SUSPENSION	RCCH053009B	1	RECH053009B	1

**INDEF M ET SPARE FOR RANGE 3**

PART NO	DESCRIPTION	DRAWING NO 1000 KG	QTY	DRAWING NO 3000 KG	QTY
201	CROSS NUT	RCDM833401A	2	REDM833401A	
201A	CROSS NUT	RCDM833405A	2	REDM833402A	
204	DISTANCE TUBE	RCDM873204A	8	REAM873204A	
204A	DISTANCE TUBE	RCDM873404A	2	REDM873204A	
205	WASHER	RCCM833205A	128	RECM833205A	
206	WASHER	FLSPWB200000	8	FLSPWB240000	
207	NUT	HNMMO20000YZ	8	HNMMO24000YZ	
9	HOOK SUSPENSION	RCCH053009B	1	RECH053009B	
9A	HOOK SUSPENSION			REDM313403A	

## 6. SPARE PARTS FOR MOTOR WITH BRAKE SYTCO BRAKE

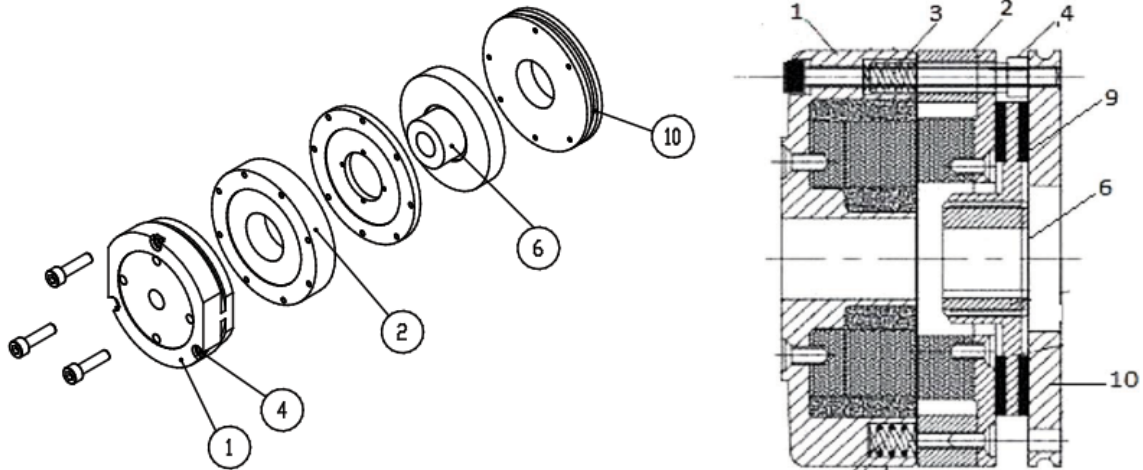

PART NO.	PART CODE	DESCRIPTION
	XBAP0060SYT	MAIN BRAKE
1	XBAP01610SSYT	STATOR
2		ARMATURE ASSEMBLY
3	XBAP87210SSYT	TUBULAR SPRING EACH SET
4		MOUNTING FLANGE ASSLY
6		BRAKE DISC & BRAKE LINER (ROTOR / GEAR HUB)
10	XBAP00510SYT	MOUNTING FLANGE



**TROLLEY BRAKE  
MAINTENANCE / REPAIR**

TROUBLE	POSSIBLE CAUSE	REQUIRED ACTION
Brake does not apply No braking action	No mains voltage. Stator (coil) open.  Armature plate Jammed (without moment)	Check supply voltage.  Brake coil resistance to be checked as per the technical data.  Springs, guide bushes must be checked and overhauled (cleaned properly).
Brake action too slow,	Oil or grease on the friction lining  Spring are present/broken  Brake lining worn-out	Replace rotor, prevent oil/grease from coming in contact with friction liner.  Dismantle brake, loosen sleeves insert new springs.  Replace rotors (armature plate and flange if very badly worn-out).

To ensure safe & trouble free operation, Spring Loaded Brakes must be checked and maintained at regular intervals. SYTCO Spring Loaded Brakes are wear – resistant and designed for trouble free longer life. The Friction Liners are subject to function -related wear. The Brakes must be checked and readjusted at regular intervals & if necessary, it should be replaced.

**PRINCIPLE OF OPERATION :** This type of brake consists of stator, Armature, Rotor & Mounting flange. Current is given to stator (coil), the armature plate is attracted to the stator against the spring force thus releasing the rotor. When current is off, strong compression springs push the armature plate back to its position thus clamping the rotor in between armature & mounting flange and providing necessary braking torque.

**INSTALLATION :** Mounting flange (10) has to be mounted on motor/machine body which should be at right angle to the motor/machine shaft as well as centered internally and externally may be with the help of spigot. The hub (6) has to be fitted on shaft with the help of key and axial retainer (circlip) and Rotor (9) on that. Stator (1) with Armature Assembly (2) has to be fitted on the Mounting flange (10) with the help of provided Allen bolt (8) through adjustment Hollow Bushes (4). The air gap should be adjusted by adjustable Hollow Bushes. To reduce air gap, rotate all bushes equally clockwise. Air gap should be within limits as per following table, initially it should be nominal.

Brake size	05	10	20	40	70	90	160	250
Nominal air gap mm	0.2	0.3	0.3	0.3	0.3	0.4	0.5	0.5
Maximum air gap mm	0.5	0.7	0.7	0.7	0.8	1.0	1.0	1.0





**MAINTANENCE :** SYTCO Fail Safe Brakes are almost maintenance free. For this periodicity depends on application to application, operating frequency, system inertia to be stopped etc. air gap can be adjusted by rotating adjustable Hollow Bushes to reduce air gap. Rotate all bushes anti-clockwise and check from all sides by filler gauge and vice-versa.

## TYPICAL CASES OF WRONG FITMENT

Typical case of uneven air gap in brake disc: This should be noticed and avoided during preventive maintenance.



Typical case of stator resting bolt head, which will restrict the stator lateral movement of brake disc: This should be noticed and avoided during preventive maintenance.

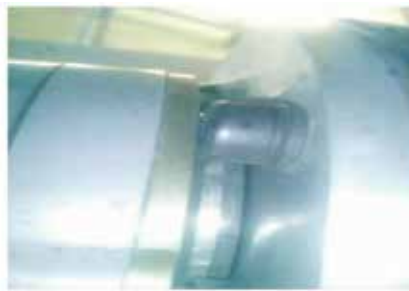

Typical case of stator fitting, the half-moon slot is to clear the bolt head, brake housing fitment wrong, which will obstruct the stator lateral movement of brake disc: This should be noticed and avoided during preventive maintenance.



## TYPICAL CASES OF WRONG WIRING

The RYB colour code of connecting cables to be maintained and wiring connections to be followed accordingly. The supply voltage is 415+/-10% for all AC brakes. The power supply fluctuations will have effect on brake coil first than motor as coil are more sensitive than motor windings.

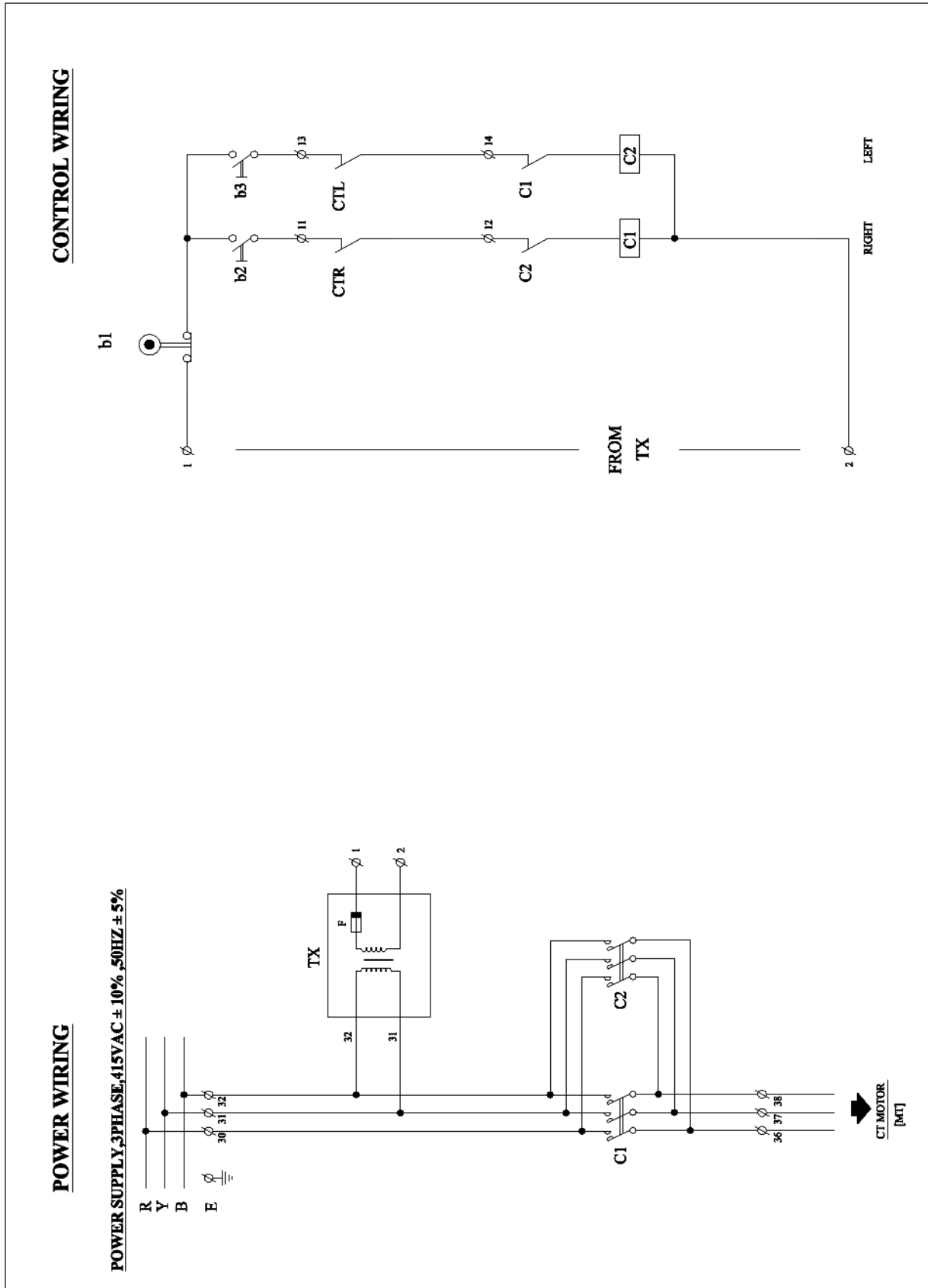



**SPARE PARTS FOR ELECTRIC TROLLEY – SINGLE ET**

CODE	DESCRIPTION	QTY
XPBE0001HHL	Indef (Giovenzana) Make 3 Way Pendant (Emergency Stop, Hoist/Low Single Speed)	1 NO
XCBP047000A	Salzer (Indef) Make 1.5 Sq.mm. 3 Core PVC Insulated Flexible Cable With Inbuilt Wirerope (1100VAC & As Per IS:694:1990)	AS PER REQ
XCTP0010AVA	Avetronics/Prince/Powerex Make Control Transformer 415V/24V,30VA	1 NO
XACP0250TMA	SCHNEIDER MAKE REVERSING CONTACTOR 9A/24V CAT NO LC2K0901 B7	1 NO

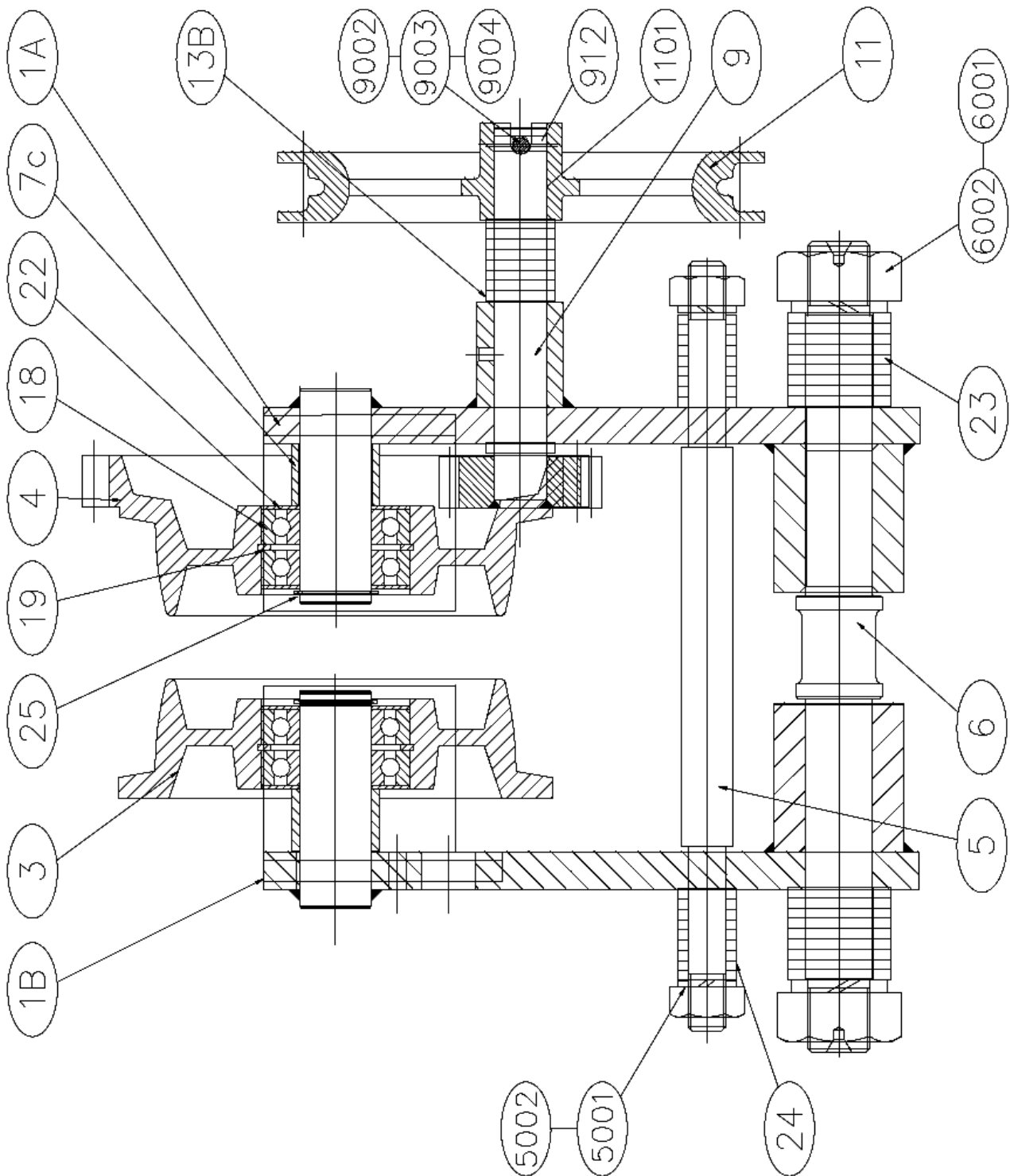

**Figure 6 5T GEARED TROLLEY ASSEMBLY**

<b>5T GEARED TROLLEY</b>			
<b>Part No.</b>	<b>Description</b>	<b>Qty.</b>	<b>Drawing Number</b>
3	PLAIN TROLLEY WHEEL	2	TJCM023003B
4	GEARED TROLLEY WHEEL	2	TJCM023004B
7C	SPACER BUSH FOR AXLE	1	TJCM883007A
9/10	PINION WITH SHAFT	1	TJCM123090A
11	HAND CHAIN WHEEL	1	TJCM021011A
13B	WASHER	4	TKCM883013A
18	BALL BEARING	8	BBR062070000
19	INTERNAL CIRCLIP	4	INCRB0900000
22	BEARING COVER	8	TQCM113022A
23	SPACER	8	PACF113023A
24	SPACER	16	TQCM113024A
25	EXTERNAL CIRCLIP	4	EXCRA0350000
912	PLAIN WASHER	1	RBCT833912A
1101	KEY	1	KB0600600180
5001	HEXAGONAL NUT	4	HNMM018000YZ
5002	FLAT SPRING WASHER	4	FLSPWB180000
6001	HEXAGONAL NUT	2	HNMM030000YZ
6002	FLAT SPRING WASHER	2	FLSPWB300000
9002	CASTLE NUT	1	CNM012000000
9003	FLAT SPRING WASHER	1	FLSPWB120000
9004	SPLIT COTTER PIN	1	SCP032025000
	JOINING LINK	1	CHJL060180YZ

<b>5T GEARED TROLLEY - R1</b>			
<b>Part No.</b>	<b>Description</b>	<b>Qty.</b>	<b>Drawing Number</b>
1A	GEAR SIDE PLATE	1	TQCM123114B
1B	PLAIN SIDE PLATE	1	TQCM123115B
5	SPACER BOLT	2	TJCM833005A
6	SUSPENSION SHAFT	1	TQAD823601B



<b>5T GEARED TROLLEY - R2</b>			
Part No.	Description	Qty.	Drawing Number
1A	GEAR SIDE PLATE	1	TQBM123114B
1B	PLAIN SIDE PLATE	1	TQBM123115B
5	DISTANCE BOLT	2	TQBD833501A
6	SUSPENSION SHAFT	1	TQBD823601B

<b>5T GEARED TROLLEY - R3</b>			
Part No.	Description	Qty.	Drawing Number
1A	GEAR SIDE PLATE	1	TQFM123114B
1B	PLAIN SIDE PLATE	1	TQFM123115B
5	DISTANCE BOLT	2	TQFM833005A
6	SUSPENSION SHAFT	1	TQFM823006B

<b>5T SPARK PROOF GEAR TROLLEY</b>			
Part No.	Description	Qty.	Drawing Number
3	PLAIN TROLLEY WHEEL	2	BJCM063003B
4	GEAR TROLLEY WHEEL	2	BJCM063004B
9	PINION *5GT-10	1	BJCM063010A
10	PINION SHAFT	1	BJCM833009A
11	HAND CHAIN WHEEL	1	BJCM063011A

<b>5T SPARK PROOF GEAR TROLLEY *R1</b>			
Part No.	Description	Qty.	Drawing Number
1A	GEAR SIDE PLATE	1	TQCM123114B
1B	PLAIN SIDE PLATE	1	TQCM123115B

<b>5T SPARK PROOF GEAR TROLLEY *R2</b>			
Part No.	Description	Qty.	Drawing Number
1A	GEAR SIDE PLATE	1	TQBM123114B
1B	PLAIN SIDE PLATE	1	TQBM123115B

<b>5T SPARK PROOF GEAR TROLLEY *R3</b>			
Part No.	Description	Qty.	Drawing Number
1A	GEAR SIDE PLATE	1	TQFM123114B
1B	PLAIN SIDE PLATE	1	TQFM123115B

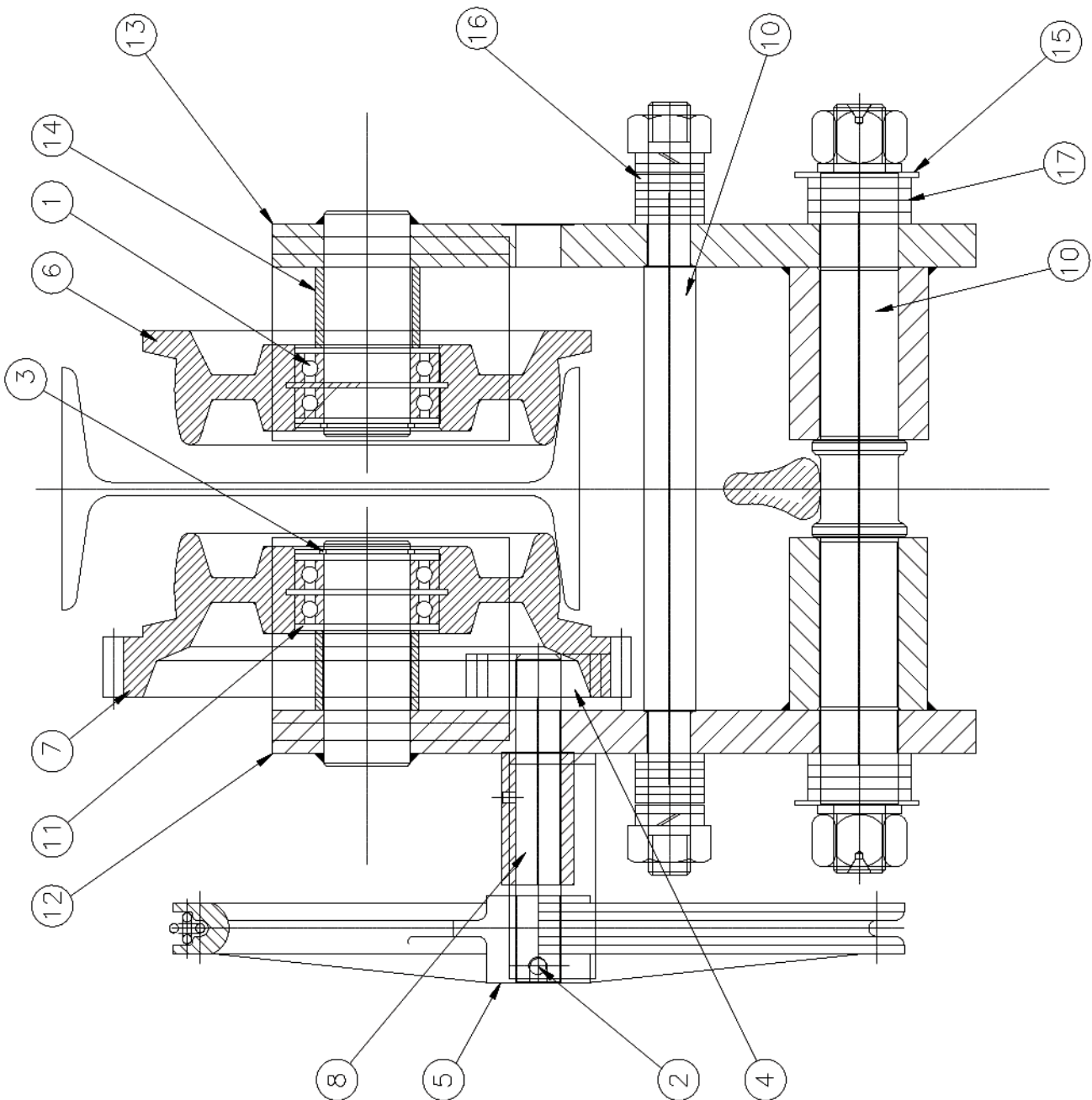

**Figure 7 10T GEARED TROLLEY ASSEMBLY**





<b>10T GEAR TROLLEY</b>			
<b>Part No.</b>	<b>Description</b>	<b>Qty.</b>	<b>Drawing Number</b>
31	BALL BEARING 6210	8	BBR062100000
2	DOWEL SPRING PIN 8*60	1	DSP080060000
3	EXTERNAL CIRCLIP A 50	4	EXCRA0500000
4	PINION *5GT-10	1	TJCM832010A
5	HAND CHAIN WHEEL	1	TKCM021011A
6	PLAIN TROLLEY WHEEL	2	TKCM023003B
7	GEAR TROLLEY WHEEL	2	TKCM023004B
8	PINION SHAFT	1	TJCM123090A
11	BEARING COVER	8	TRCM113022A
14	SPACER BUSH FOR AXLE	4	TRCM883007A
15	SPACER 33 I.D * 50 * 5	2	PACF113023A
16	WASHER 26 * 33.7 * 5	14	TKCM883013A
17	SPACER	6	TRCM113023A
	JOINING LINK	1	CHJL060180YZ

<b>10T GEAR TROLLEY - R1</b>			
<b>Part No.</b>	<b>Description</b>	<b>Qty.</b>	<b>Drawing Number</b>
12	GEAR SIDE PLATE	1	TRCM123114B
13	PLAIN SIDE PLATE	1	TRCM123115B
10	DISTANCE BOLT	2	TRBD833502A
9	SUSPENSION SHAFT	1	TRAD823601B

<b>10T GEAR TROLLEY - R2</b>			
<b>Part No.</b>	<b>Description</b>	<b>Qty.</b>	<b>Drawing Number</b>
12	GEAR SIDE PLATE	1	TRBM123114B
13	PLAIN SIDE PLATE	1	TRBM123115B
10	DISTANCE BOLT	2	TRBD833501A
9	SUSPENSION SHAFT	1	TRBD823601B

<b>10T GEAR TROLLEY - R3</b>			
Part No.	Description	Qty.	Drawing Number
12	GEAR SIDE PLATE	1	TRFM123114B
13	PLAIN SIDE PLATE	1	TRFM123115B
10	DISTANCE BOLT	2	TRFM833005A
9	SUSPENSION SHAFT	1	TRFM823006A

<b>10T SPARK PROOF GEAR TROLLEY</b>			
5	HAND CHAIN WHEEL	1	BKCM063011A
6	PLAIN TROLLEY WHEEL	2	BKCM063003B
7	GEAR TROLLEY WHEEL	2	BKCM063004B
8	PINION SHAFT	1	BJCM833009A
8	PINION	1	BJCM063010A

<b>10T SPARK PROOF GEAR TROLLEY *R1</b>			
Part No.	Description	Qty.	Drawing Number
12	GEAR SIDE PLATE	1	TRCM123114B
13	PLAIN SIDE PLATE	1	TRCM123115B

<b>10T SPARK PROOF GEAR TROLLEY *R2</b>			
Part No.	Description	Qty.	Drawing Number
12	GEAR SIDE PLATE	1	TRBM123114B
13	PLAIN SIDE PLATE	1	TRBM123115B

<b>10T SPARK PROOF GEAR TROLLEY *R3</b>			
Part No.	Description	Qty.	Drawing Number
12	GEAR SIDE PLATE	1	TRFM123114B
13	PLAIN SIDE PLATE	1	TRFM123115B

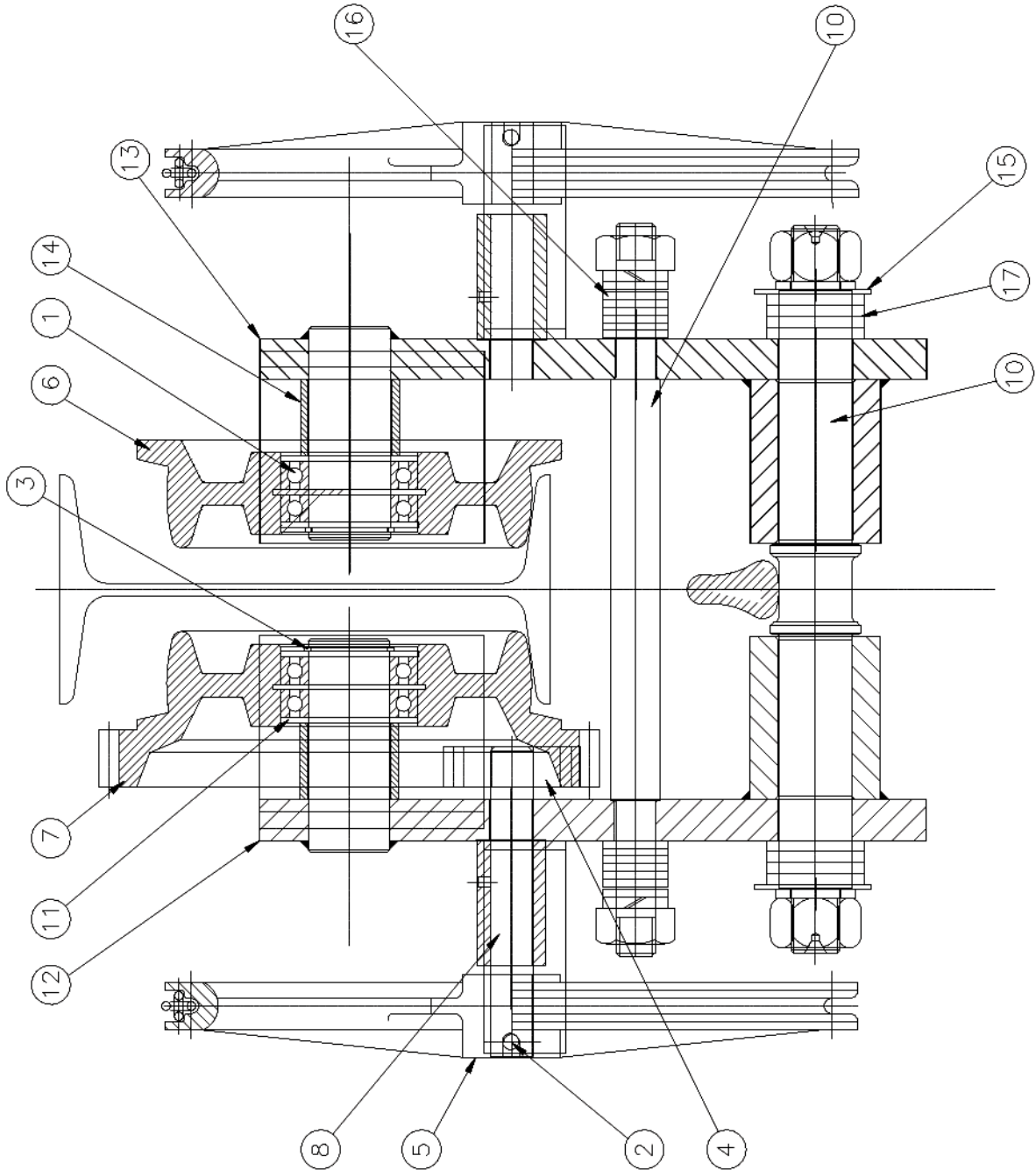

**Figure 8 15T / 20T GEARED TROLLEY ASSEMBLY**

<b>15T/20T GEAR TROLLEY</b>			
<b>Part No.</b>	<b>Description</b>	<b>Qty.</b>	<b>Drawing Number</b>
1	BALL BEARING 6210	16	BBR062100000
2	DOWEL SPRING PIN 8*60	2	DSP080060000
3	EXTERNAL CIRCLIP A 50	8	EXCRA0500000
5	HAND CHAIN WHEEL	2	TKCM021011A
6	PLAIN TROLLEY WHEEL	4	TKCM023003B
7	GEAR TROLLEY WHEEL	4	TKCM023004B
4/8	PINION SHAFT	2	TJCM123090A
11	BEARING COVER	16	TRCM113022A
14	SPACER BUSH FOR AXLE	8	TRCM883007A
15	SPACER 33 I.D * 50 * 5	4	PACF113023A
16	WASHER 26 * 33.7 * 5	4	TKCM883013A
17	SPACER	12	TRCM113023A
	JOINING LINK	1	CHJL060180YZ

<b>15T/20T GEAR TROLLEY - R1</b>			
<b>Part No.</b>	<b>Description</b>	<b>Qty.</b>	<b>Drawing Number</b>
12	GEAR SIDE PLATE	2	TLCM123114B
13	PLAIN SIDE PLATE	2	TLCM123115B
10	DISTANCE BOLT	4	TRBD833502A
9	LOAD AXLE	2	TLDM823124A

<b>15T/20T GEAR TROLLEY - R2</b>			
<b>Part No.</b>	<b>Description</b>	<b>Qty.</b>	<b>Drawing Number</b>
12	GEAR SIDE PLATE	2	TLBM123114B
13	PLAIN SIDE PLATE	2	TLBM123115B
10	DISTANCE BOLT	4	TRBD833501A
9	LOAD AXLE	2	TLEM823124A



<b>15T/20T GEAR TROLLEY - R3</b>			
Part No.	Description	Qty.	Drawing Number
12	GEAR SIDE PLATE	2	TLFM123114B
13	PLAIN SIDE PLATE	2	TLFM123115B
10	DISTANCE BOLT	4	TRFM833005A
9	LOAD AXLE	2	TLFM823124A

<b>15T/20T SPARK PROOF GEAR TROLLEY</b>			
Part No.	Description	Qty.	Drawing Number
5	HAND CHAIN WHEEL	1	BKCM063011A
6	PLAIN TROLLEY WHEEL	2	BKCM063003B
7	GEAR TROLLEY WHEEL	2	BKCM063004B
8	PINION SHAFT	1	BJCM833009A
8	PINION	1	BJCM063010A

<b>15T/20T SPARK PROOF GEAR TROLLEY *R1</b>			
Part No.	Description	Qty.	Drawing Number
12	GEAR SIDE PLATE	2	TLCM123114B
13	PLAIN SIDE PLATE	2	TLCM123115B

<b>15T/20T SPARK PROOF GEAR TROLLEY *R2</b>			
Part No.	Description	Qty.	Drawing Number
12	GEAR SIDE PLATE	2	TLBM123114B
13	PLAIN SIDE PLATE	2	TLBM123115B

<b>15T/20T SPARK PROOF GEAR TROLLEY *R3</b>			
Part No.	Description	Qty.	Drawing Number
12	GEAR SIDE PLATE	2	TLFM123114B
13	PLAIN SIDE PLATE	2	TLFM123115B

## HERCULES HOISTS LIMITED



WARRANTY VALID ONLY IF INSTALLATION CERTIFIED BY HHL AUTHORISED PERSONNEL

DOWNLOAD genuine indef APP TO REGISTER YOUR HOISTS & CERTIFICATION REQUEST

Please ask for a copy of our on-line certification report to ensure your warranty  
Register your Company & you purchased Product on our App and get 3 (three) month additional warranty

## HERCULES HOISTS LIMITED

SERVICE CONTACT : +91 8669994119

service@indef.com - ANYTIME  
www.indef.com/service - ANYTIME

Issue Date	Revision	Revision summary
21.10.2020	R0	-
16.03.2022	R1	Part Codes & Service No. Changed

## HERCULES HOISTS LIMITED

C.T.S. No.43/2B, 43/5, 45/2, Near Naik Navre Chemicals  
At Village - Dhamani, Tal. - Khalapur, Dist. - Raigad, Khopoli - 410202 (M.S.)  
E-mail : csga@indef.com  
Tel. 02192-662502/503/555 Fax : 02192-662504

501-504, 5th Floor , Shelton Cubix, Plot No. 87, CBD Belapur,  
Navi Mumbai 400 614. Maharashtra, INDIA  
P: +91 22-45417300

[www.indef.com](http://www.indef.com)